

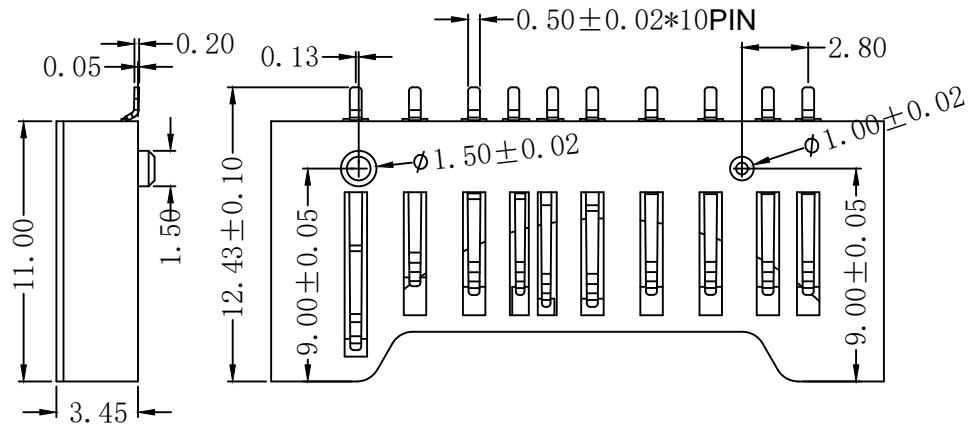

7		8	
REV:	ECN. NO.	NAME	DATE

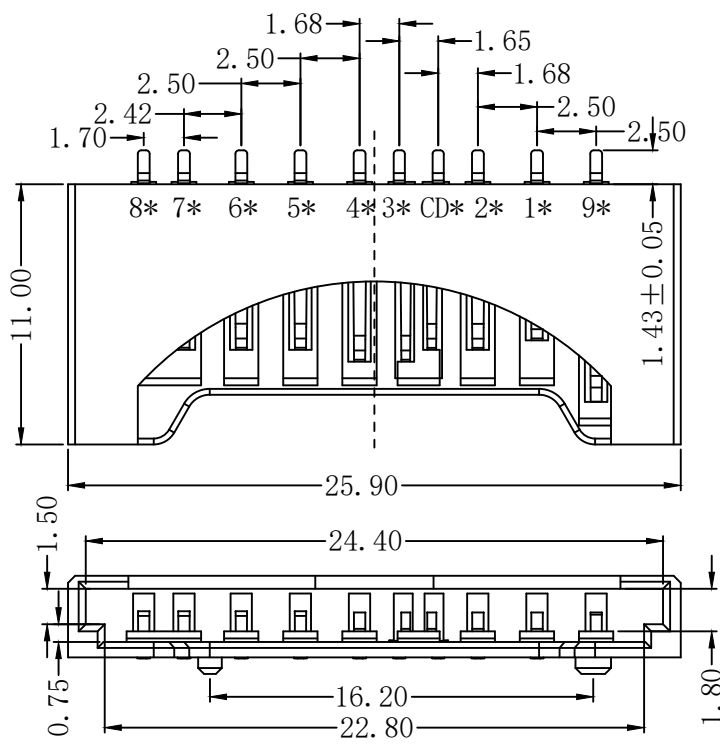

NOTES:
 Current Rating: 0.5A AC,DC
 Temperature Range: -20°C~+60°C
 Contact Resistance: 40mΩ max
 Insulation Resistance: 1000MΩ min
 Withstanding Voltage: 500V
 AC/minute
 Material: Insulation:HI-Temp plastic UL 94V-0 Rated.
 Contact:Phsopror Bronze.

RoHS Compliant

PIN Assignment			
PIN*	Name	Type	Card Detelct/bete line[Bit3]
1	CD/DAT3	I/O/PP	Cornard/response
2	CMD	PP	Supply voltage
3	V551	S	Supply voltage ground
4	VDD	S	Supply voltage
5	CLK	I	Clock
6	V552	S	Supply voltage ground
7	DAT0	I/O/PP	Date line [Bit0]
8	DAT1	I/O/PP	Date line [Bit1]
9	DAT2	I/O/PP	Date line [Bit2]

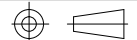
MILLIMETERS X.° ± 2° .X ± 0.30 .XX ± 0.20 .XXX ± 0.10	INCH X.° ± 2° .X ± 0.010 .XX ± 0.008 .XXX ± 0.004	 VITALCON a vital connector company	FOR YOUR VITAL CONNECTION	
TITLE: SD CARD H=3.45 LCP黑胶 端子C5191				
DRAWN BY: Zou Long	PART NO: VTC402013402-A	REV: A		
CHECKED BY: Bob	SIZE: A4	UNIT:mm	SHEET:1 OF 2	FCN: E1
APPROVED BY: QPF	PROJECTION		http://www.vitalconn.com	

REV:	ECN. NO.	NAME	DATE

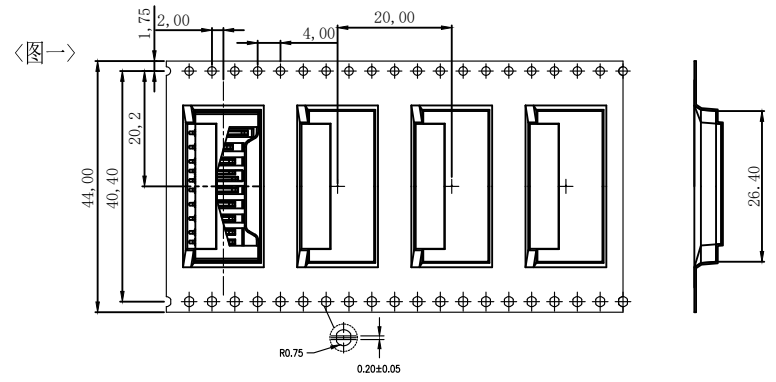

<TABLE 1> PACKAGING QUANTITY

QTY/REEL	REEL/CARTON	QTY/CARTON
700	6	4200

<图三>

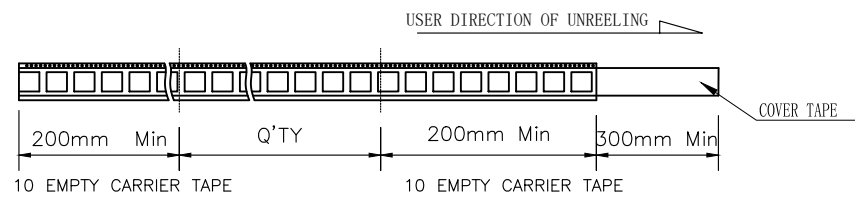
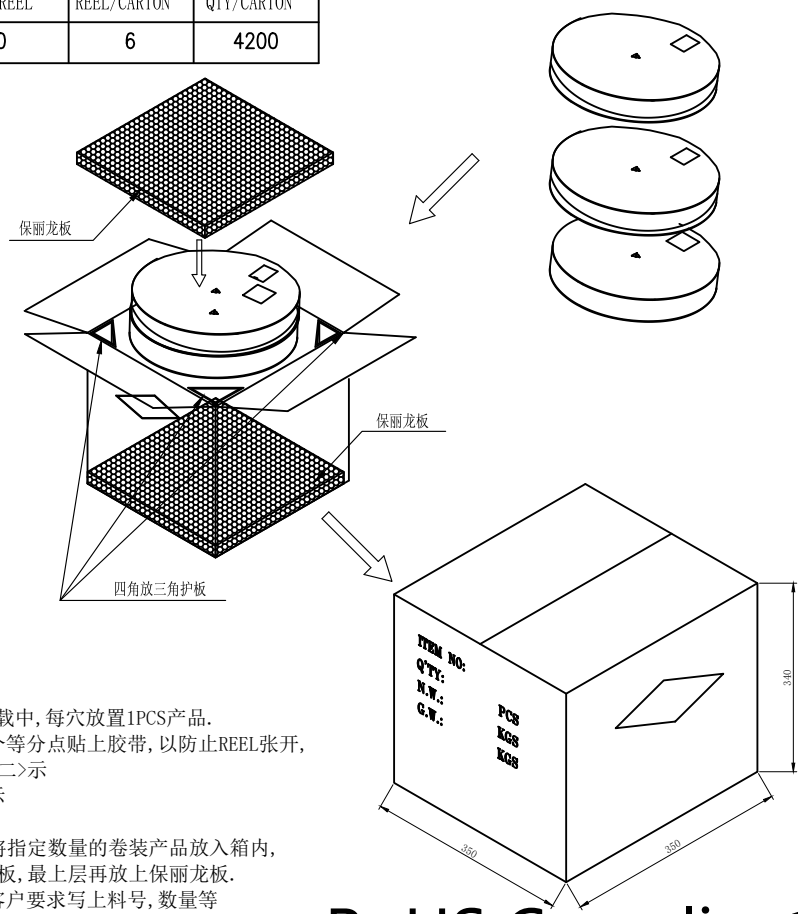

<图二>

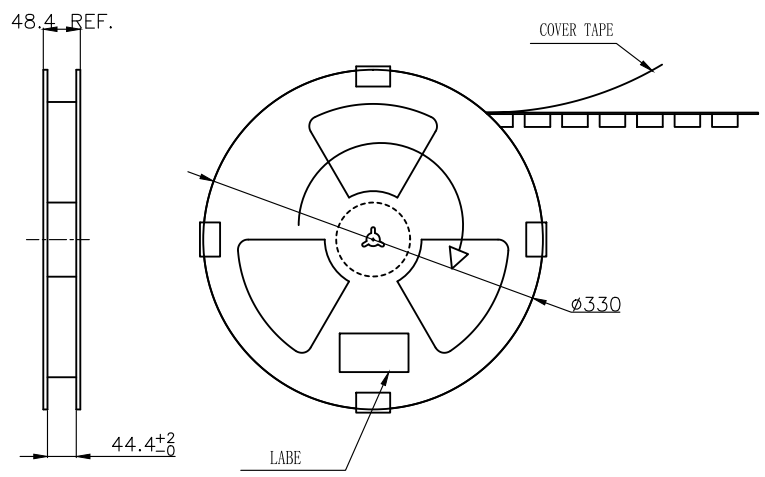

COVER TAPE PEELING FORCE: 20gf~120gf

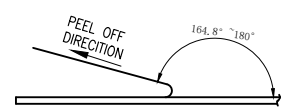

NOTE:

1. 依<图一>示放置产品于下载中, 每穴放置1PCS产品.
2. 包装机包好后, 在REEL的个等分点贴上胶带, 以防止REEL张开, 每REEL贴1PCS标签, 如<图二>示
3. 包装数量见如<TABLE 1>示
4. 包装成箱见如<图三>示
箱底放保利龙板, 再依次将指定数量的卷装产品放入箱内, 四角分别放入四个三角护板, 最上层再放上保利龙板.
5. 封箱, 在封好的纸箱上按客户要求写上料号, 数量等

RoHS Compliant

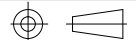
MILLIMETERS X.° ± 2° .X ± 0.30 .XX ± 0.20 .XXX ± 0.10	INCH X.° ± 2° .X ± 0.010 .XX ± 0.008 .XXX ± 0.004	 a vital connector company		FOR YOUR VITAL CONNECTION	
				TITLE:	SD CARD H=3.45 LCP黑胶 端子C5191
DRAWN BY:	Zou Long	PART NO:	VTC402013402-A	REV: A	
CHECKED BY:	Bob	SIZE: A4	UNIT:mm	SHEET:2 OF 2	FCN: E1
APPROVED BY:	QPF	PROJECTION		http://www.vitalconn.com	