

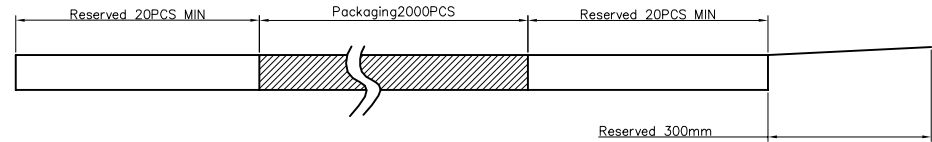

7		8	
REV:	ECN. NO.	NAME	DATE
A0	—	sun	2025.07.18

NOTES:

- 1: Packing quantity per plate: 2000PCS/Plate
- 2: Loading and packing method

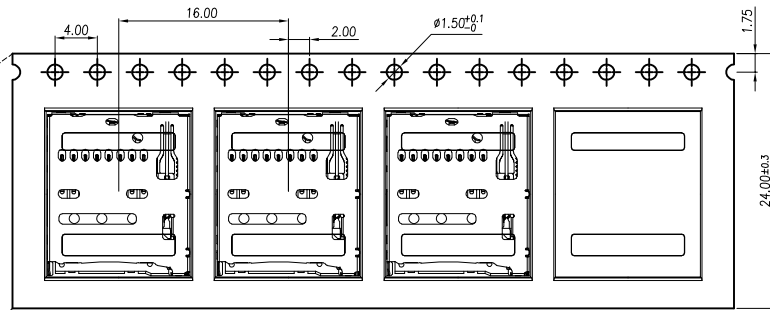

3: Total packaging: 20000PCS/Box

Direction of use

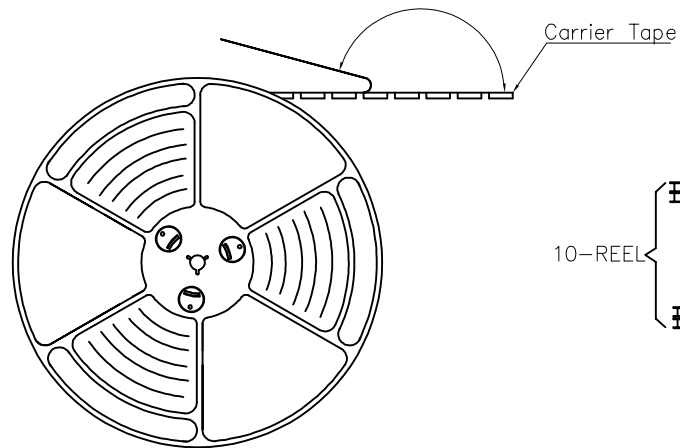

The bottom and top of the carton Pad it with a piece of pearl cotton

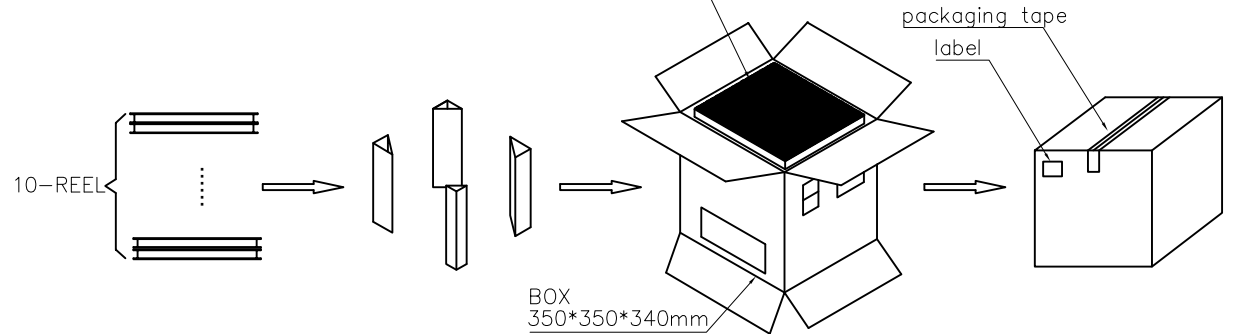

For technical support, please send an email to support@vitalconn.com

MILIMETERS X.° ±2° .X ±0.30 .XX ±0.20 .XXX ±0.10	INCH X.° ±2° .X ±0.012 .XX ±0.008 .XXX ±0.004	VITALCONN a vital connector company	FOR YOUR VITAL CONNECTION	
DRAWN BY: Zou Long		TITLE:	1.25H Push_Push TF CONN.	
CHECKED BY: Bob		PART NO:	C102316832E1	REV: A
APPROVED BY: QPF		SIZE: A4	UNIT:mm	SHEET:2 OF 2
PROJECTION			http://www.vitalconn.com	