

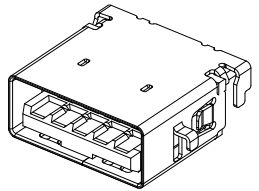

REV:	ECN. NO.	NAME	DATE

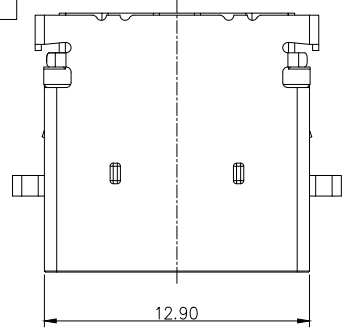

3D VIEW

PIN NO.	1	2	3	4	
SIGNAL NAME	VBUS	D-	D+	GND	
REMARK	USB2.0 CONTACT PIN				
PIN NO.	5	6	7	8	9
SIGNAL NAME	SSRX-	SSRX+	GND	SSTX-	SSTX+
REMARK	USB3.0 CONTACT PIN				

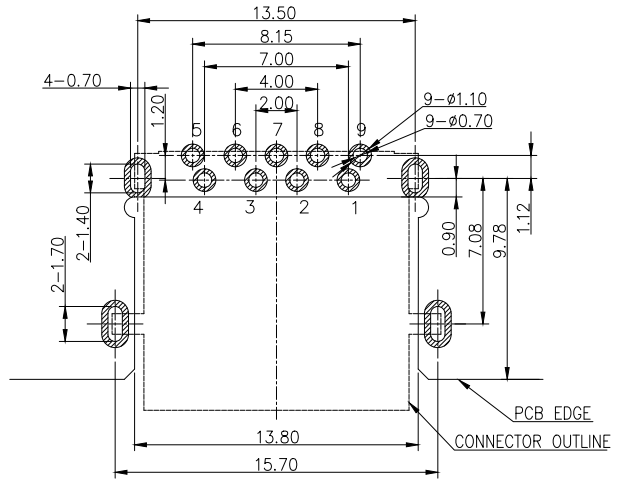
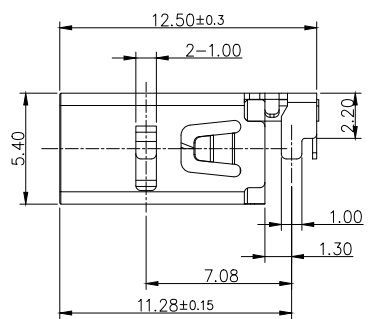
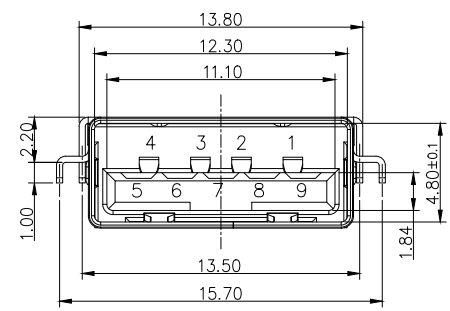

TOLERANCE: ±0.05, THICKNESS: 1.0~1.2mm
RECOMMENDED PCB LAYOUT
 (TOP VIEW)

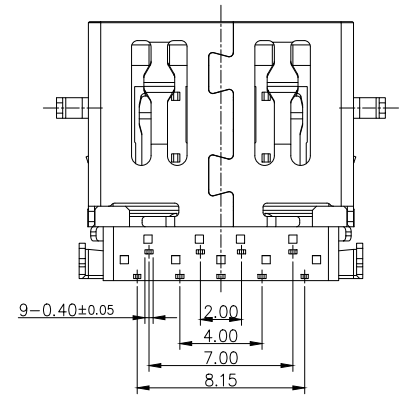

- NOTE:
- MATERIAL:
 - HOUSING: HIGH TEMPERATURE PLASTIC UL94V-0, BLACK.
 - CONTACT: C5191 T=0.20mm
 - SHELL: SUS304 T=0.30mm
 - ELECTRICAL CHARACTERISTICS:
 - CONTACT RESISTANCE: 30mΩ Max
 - CONTACT CURRENT RATING: 1.5A
 - DIELECTRIC WITHSTANDING VOLTAGE: 100V AC R.M.S.
 - INSULATION RESISTANCE 100MΩ Min
 - OPERATING TEMPERATURE: -40°C~85°C
 - RATE VOLTAGE: 30V DC
 - MECHANICAL CHARACTERISTICS:
 - INSERTION FORCE: 35N Max
 - EXTRACTION FORCE: 10N Min INITIAL, 8N Min AFTER TEST
 - DURABILITY: 1500 CYCLES
 - PLATING:
 - TERMINAL CONTACT: G/F PLATING ON CONTACT AREA 80u"MIN Matte Tin PLATED ON SOLDER AREA 30u" MIN. Ni UNDERPLATED OVERALL
 - SHELL: 50u"MIN. NICKEL ALL OVER
 - SALT SPRAY: 24H

MILLIMETERS	INCH
X° ±2°	X° ±2°
.X ±0.30	.X ±0.012
.XX ±0.20	.X ±0.008
.XXX ±0.10	.X ±0.004



FOR YOUR VITAL CONNECTION

TITLE:	USB3.0 AF 90°反向沉板2.2H				
DRAWN BY:	Zou Long	PART NO:	UA2623532E1	REV: A	
CHECKED BY:	Bob	SIZE: A4	UNIT:mm	SHEET:1 OF 2	FCN: E1
APPROVED BY:	QPF	PROJECTION		http://www.vitalconn.com	

For technical support, please send an email to support@vitalconn.com



Direction of use →

REV:	ECN. NO.	NAME	DATE

A

B

C

D

E

F

A

B

C

D

E

F

NOTES:

- 1、Packing quantity per plate: 400PCS/Plate
- 2、Loading and packing method

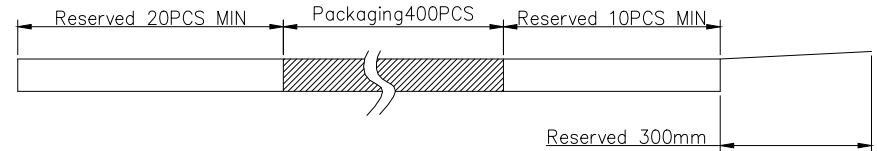

3、Total packaging: 3200PCS/Box

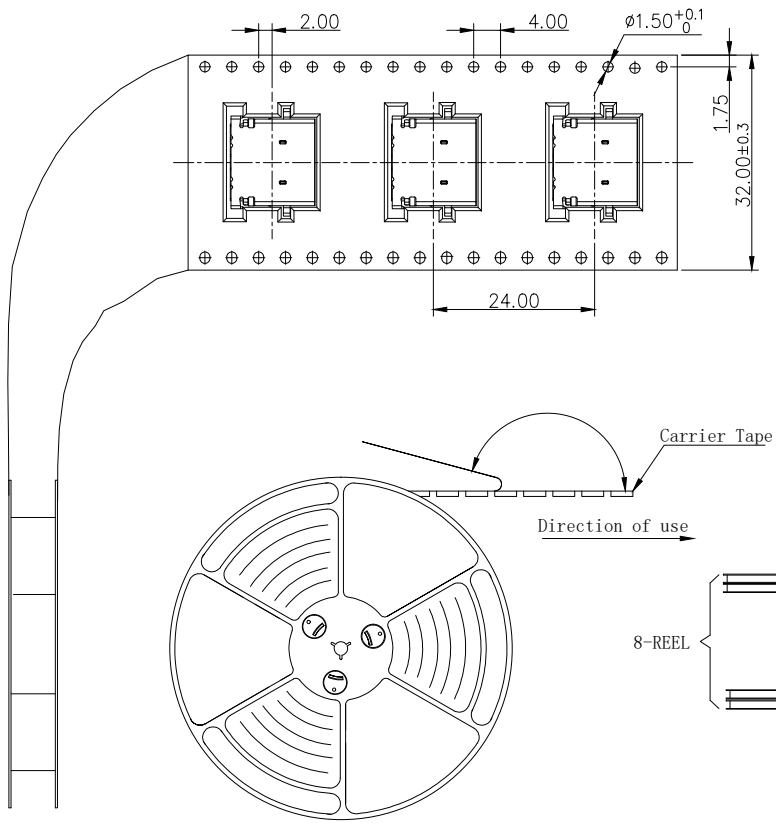

The bottom and top of the carton Pad it with a piece of pearl wool

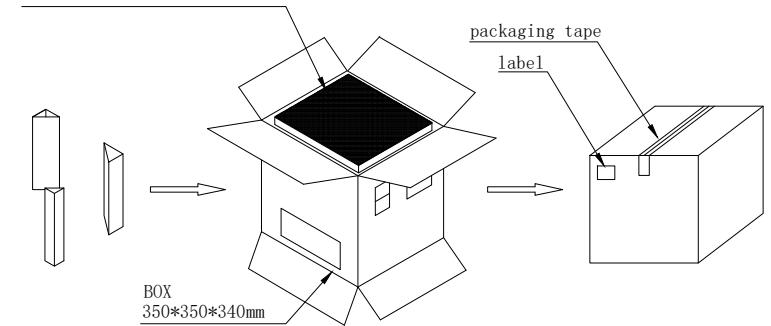

Part Number	Description	Quantity
303020127	Carrierband (Lucent, PET W=32 PH=24)	82.56M
303040009	Box (K=K, T=7.0, 350*350*340)	1PCS
303060001	PE Bag (T=0.08mm, 730*760*730)	1PCS
303070014	Self-adhesive (W=25.50)	84.96M
303110001	Beam (K=K, T=7.0, 95*95*290)	4PCS
303130001	Pearl Wool (340*340*18)	2PCS
303180021	REEL (BLUE, 13Inches*32mm, φ330)	8PCS
UA2623532E1	USB3.0 AF 90° 反向沉板2.2H	3200PCS

MILLIMETERS X°. ±2° .X ±0.30 .XX ±0.20 .XXX ±0.10		INCH X°. ±2° .X ±0.012 .X ±0.008 .X ±0.004		 a vital connector company	FOR YOUR VITAL CONNECTION		
DRAWN BY: Zou Long		PART NO: UA2623532E1			REV: A		
CHECKED BY: Bob		SIZE: A4		UNIT:mm	SHEET:2 OF 2	FCN: E1	
APPROVED BY: QPF		PROJECTION				http://www.vitalconn.com	

For technical support, please send an email to support@vitalconn.com