

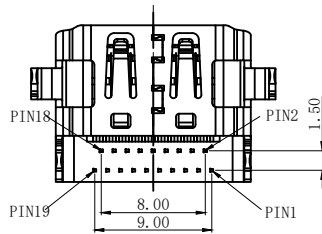

7		8	
REV:	ECN. NO.	NAME	DATE

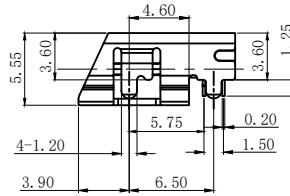
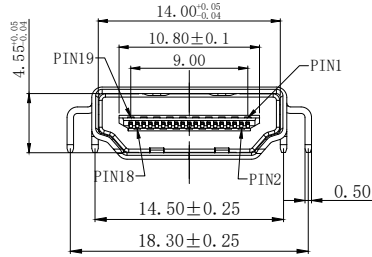
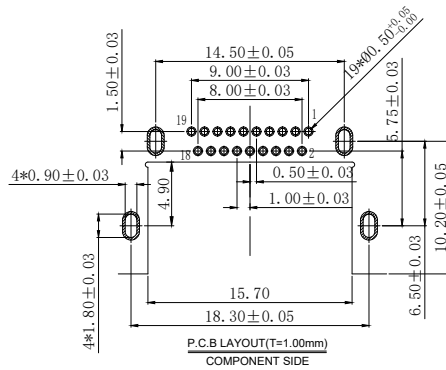
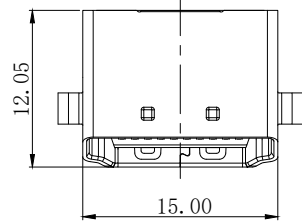

SPECIFICATIONS:

- ELECTRICAL CHARACTERISTICS
 - CURRENT RATING: 0.5 AMP
 - VOLTAGE RATING: 40 V
 - CONTACT RESISTANCE: 30MILLIOHMS MAX
 - INSULATION RESISTANCE: 100M MIN. @500V DC
 - DIELECTRIC WITHSTANDING VOLTAGE: 500V AC FOR 1 MINUTE
- MECHANICAL CHARACTERISTICS:
 - INSERTION FORCE : 4.5KGF MAX.
 - WITHDRAWING FORCE : 1KGF ~ 4KGF.
- LIFE TEST: 10000 CYCLES
- OPERATING TEMPERATURE: -25° C TO +85° C

PART No. :

HM A 2 01 079 2 E1

HDMI
HDMI Type A
Female
PLATING:
01:G/F+MATTE TIN

Running Code
PAKING:
2: REEL
SERIAL NO.

SHELL	1	C2680R-H Ni T=0.5MM, 50u~MIN. NICEL ALL OVER
TERMINAL	19	C2680R-H G/F;MATTE TIN
HOUSING	1	LCP E130i UL94V-0 BLACK
PART NAME	QTY	MATERIAL PLATING & COLOR

MILLIMETERS	INCH
X°±2°	X°±2°
.X±0.38	.XX±0.015
.XX±0.25	.XXX±0.010
.XXX±0.15	.XXXX±0.006



FOR YOUR
VITAL CONNECTION

TITLE: HDMI正向沉板铜壳镀镍窗口斜口两K脚两直脚

DRAWN BY:	Zou Long	PART NO:	HMA2010792E1	REV: A0
CHECKED BY:	Bob	SIZE: A1	UNIT:mm	SHEET:1 OF 2
APPROVED BY:	QPF	PROJECTION		FCN: E1
For technical support, please send an email to support@vitalconn.com		http://www.vitalconn.com		



7		8	
REV:	ECN. NO.	NAME	DATE

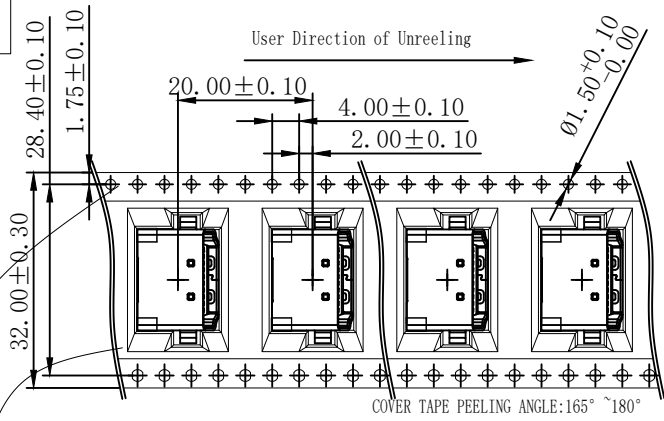

NOTES

1. NUMBER OF CONNECTORS: 500PCS/REEL
2. LEAD TAPE LENGTH

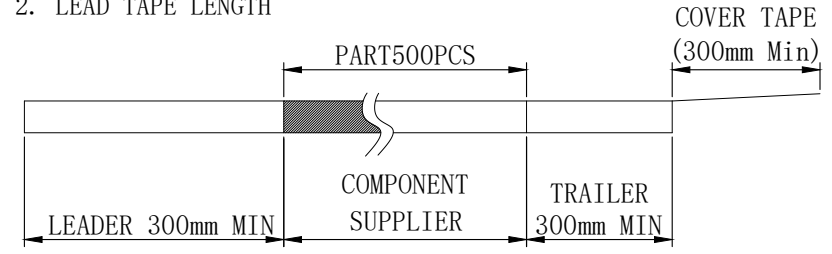

3. QUANTITY: 3000PCS/CARTON

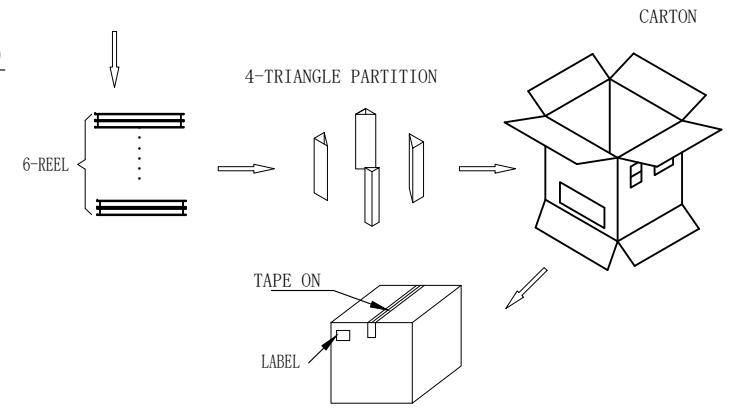
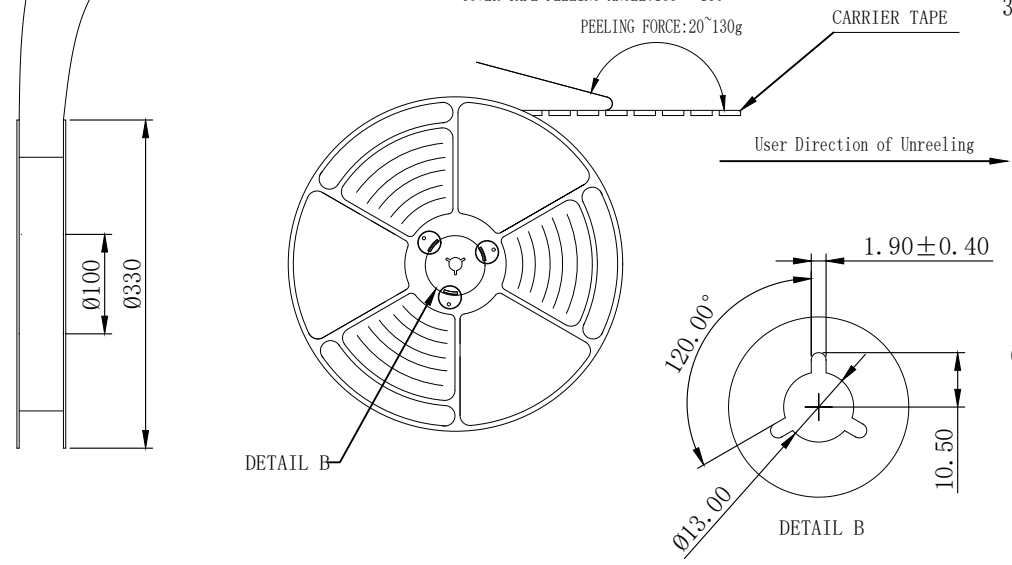

MILLIMETERS	INCH
X°±2°	X°±2°
.X±0.38	.XX±0.015
.XX±0.25	.XXX±0.010
.XXX±0.15	.XXXX±0.006



FOR YOUR VITAL CONNECTION

DRAWN BY:	Zou Long	PART NO:	HMA2010792E1	REV: A0
CHECKED BY:	Bob	SIZE: A1	UNIT:mm	SHEET:2 OF 2
APPROVED BY:	QPF	PROJECTION		FCN: E1
support@vitalconn.com		http://www.vitalconn.com		

For technical support, please send an email to support@vitalconn.com