

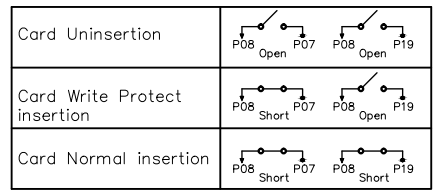

REV:	ECN. NO.	NAME	DATE
A0	----	-----	04-07-2026

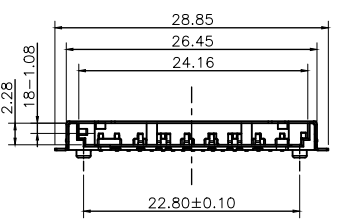
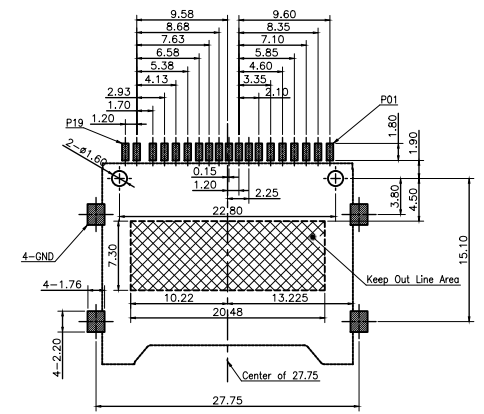
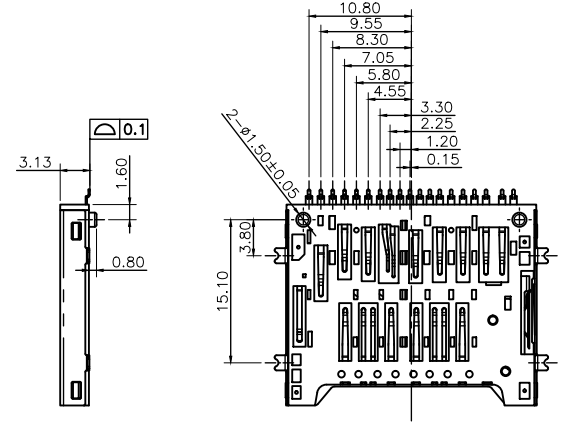
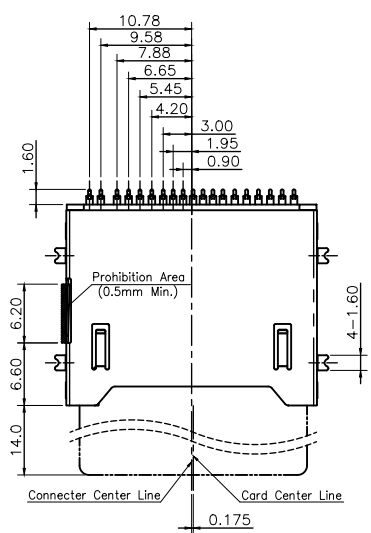

- Note:
- Material:
    - 1-1. Plastic: LCP, S475, Black, HF, UL94V-0
    - 1-2. Contact: C5210
    - 1-3. Shell: SUS304
  - Plating:
    - 2-1. Contact:
      - Contact Area: Au 1μ" min. Plating. Over Ni 50μ" min.
      - Soldertail: Matte Tin 100μ" min. Plating. Over Ni 50μ" min.
    - 2-2. Shell:
      - Ni 50μ" min. Over All, Solder Foot 1μ" Gold Over Ni
  - Contact And Tail Coplanarity To Be 0.10mm max.
  - Electrical Characteristics:
    - 4-1. Contact Current Rating: 0.5Amperes.
    - 4-2. Dielectric Withstanding Voltage: AC500V r.m.s.
    - 4-3. Insulation Resistance: 1000 Megohms
    - 4-4. Contact Resistance: 100 mΩ Maximum.
  - Mechanical Characteristics:
    - 5-1. Mating Cycles: 10,000 Cycles.
  - Environmental:
    - 6-1. Operating Temperature: -25° C ~ +85° C.
    - 6-2. Salty spray: 48H

Pin Assignment

Pin#	Name	Description	Pin#	Name	Description
P01	VSS3	Supply Voltage Ground	P11	VDD1	Supply Voltage (3.3V)
P02	DAT2	Data Line [Bit 2]	P12	D1-	Deferential Data 1-
P03	D0+	Deferential Data 0+	P13	CLK	Clock
P04	CD/DAT3	Card Detect/Data Line [Bit 3]	P14	D1+	Deferential Data 1+
P05	D0-	Deferential Data 0-	P15	VSS2	Supply Voltage Ground
P06	CMD	Command/Response	P16	VSS5	Supply Voltage Ground
P07	CD	Card Detect	P17	DAT0	Data Line [Bit 0]
P08	VSS1	Supply Voltage Ground	P18	DAT1	Data Line [Bit 1]
P09	VSS4	Supply Voltage Ground	P19	WP	Write Protect
P10	VDD2	Supply Voltage (1.8V)			

DIMENSIONS IN: mm  
UNLESS OTHERWISE SPECIFIABLE  
DIMENSION TOLERANCE  
X.X: ±0.35  
X.XX: ±0.25  
X.XXX: ±0.10  
ANGULAR: ± 2°



FOR YOUR VITAL CONNECTION

TITLE: SD4.0 Topmount H3.13 SMT Non-push

DRAWN BY:	Zou Long	PART NO:	CT125131301E7	SHEET:	1 OF 2	REV:	A0
CHECKED BY:	Bob	DWG NO:	D-CT125131301E7	SIZE:	A4	UNIT:	mm
APPROVED BY:	QPF	PROJECTION:		FCN:	E7		

For technical support, please send an email to support@vitalconn.com

http://www.vitalconn.com



REV:	ECN. NO.	NAME	DATE
A0	----	-----	04-07-2026

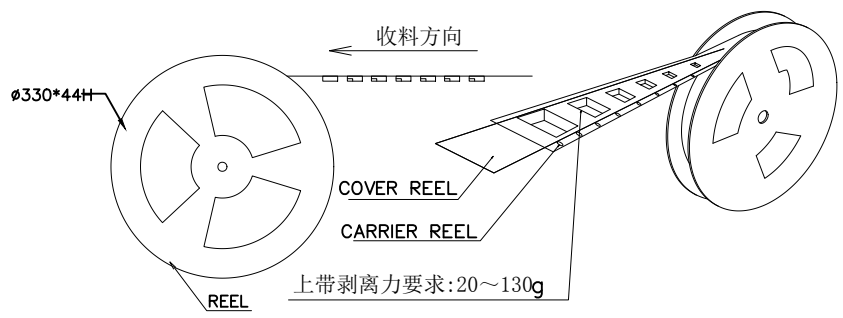

标签粘贴处 (朝卷装包材椭圆孔一侧)

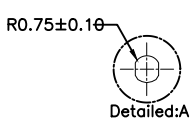
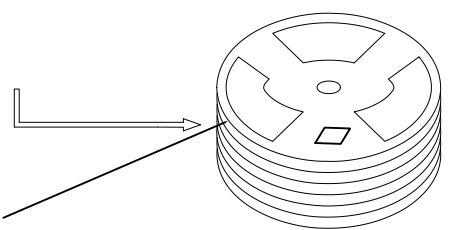

前(内圈)空10格不装产品  
后(外圈)空8格不装产品,  
上带空留120mm  
取料方向 卷装时,载带边的椭圆孔对自己

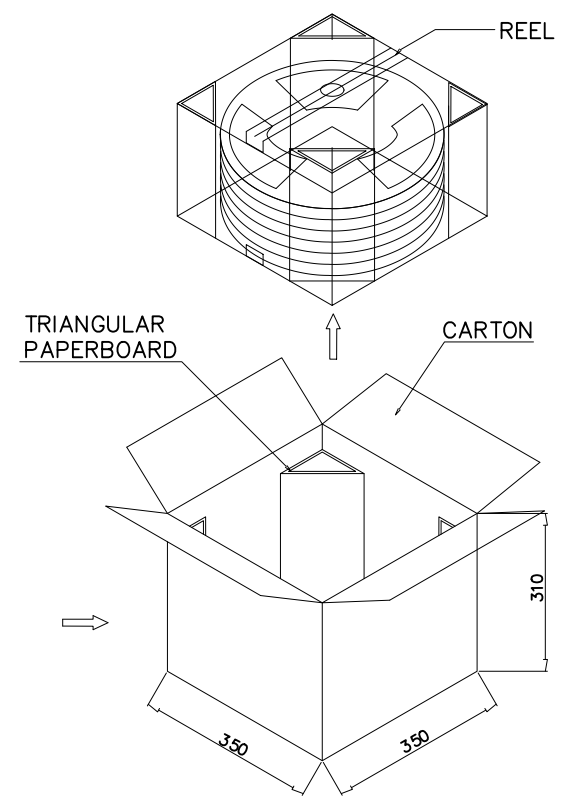
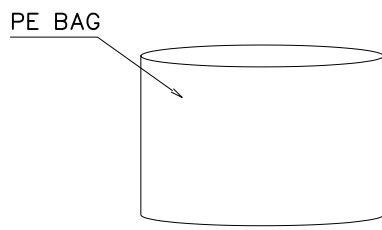
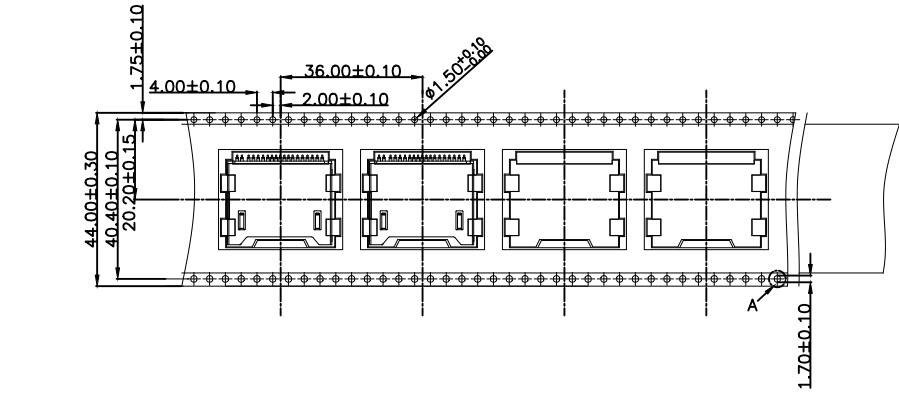

PACKING INFORMATION

PART NAME	SD 4.0 CONN
QUANTITY OF PER REEL	380PCS/REEL
QUANTITY OF PER CARTON	6*380=2280PCS/CARTON
REEL TYPE	φ330x44H
CARTON SIZE	350*350*310

DIMENSIONS INIT: mm	
UNLESS OTHERWISE SPECIFIABLE	
DIMENSION	TOLERANCE
X.X:	±0.35
X.XX:	±0.25
X.XXX:	±0.10
ANGULAR:	± 2°



FOR YOUR VITAL CONNECTION

TITLE: SD4.0 Topmount H3.13 SMT Non-push

DRAWN BY:	Zou Long	PART NO:	CT125131301E7	SHEET:	2 OF 2	REV:	A0
CHECKED BY:	Bob	DWG NO:	D-CT125131301E7	SIZE:	A4	UNIT:	mm
APPROVED BY:	QPF	PROJECTION:		http://www.vitalconn.com			

For technical support, please send an email to support@vitalconn.com