

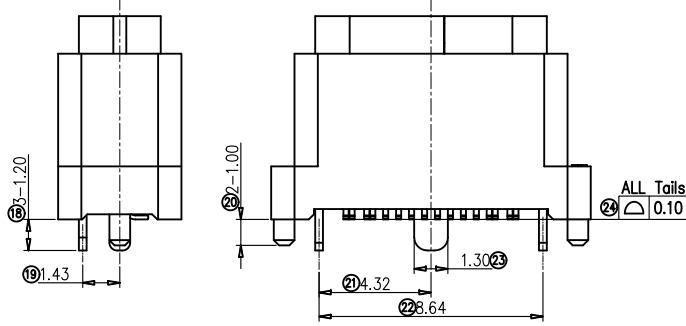

REV:	ECN. NO.	NAME	DATE
A0	----	-----	04-28-2026

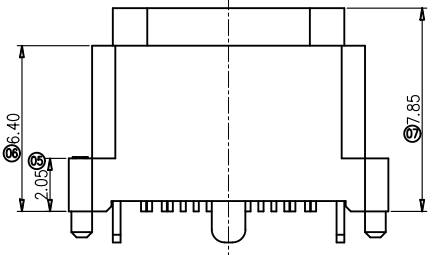

- NOTES:
- MATERIAL:
 - HOUSING: PA10T UL94V-0; COLOR: BLACK
 - CAP: LCP UL94V-0; COLOR: BLACK
 - CONTACT: C7025
 - SHELL: SUS304
 - MID PLATE: SUS301
 - WATERPROOF RING: HCR 9150 UE
 - FINISH:
 - TERMINAL: 1u" Au PLATED ON CONTACT AREA; G/F PLATED ON SOLDER AREA; Ni 30u" MIN. UNDERPLATED OVERALL.
 - SHELL: Ni 50u" MIN. PLATED OVERALL
 - MID PLATE: CLEANING.
 - ELECTRICAL SPECIFICATION:
 - RATED CURRENT: VBUS PIN 5A; GND PIN 1.25A; Other pin 0.25A
 - CONTACT RESISTANCE: 40mΩ MAX(INITIAL). 50mΩ MAX (AFTER).
 - INSULATION RESISTANCE: 100MΩ MIN.
 - DIELECTRIC WITHSTANDING VOLTAGE: 100V AC R.M.S.
 - MACHINERY SPECIFICATION:
 - MATING FORCE: 5N~20N. UNMATING FORCE: 8N~20N. (AFTER TEST:6N~20N).
 - DURABILITY: 10000 CYCLES MIN.
 - ENVIRONMENTAL SPECIFICATION:
 - OPERATING CONDITION: TEMPERATURE -40°C~+85°C; HUMIDITY 80% R.H MAX
 - SALT SPRAY: 24H
 - SOLDER ABILITY: 245±5°C, 5±0.5s
 - IR REFLOW: THE PEAK TEMPERATURE ON THE BOARD SHALL BE MAINTAINED FOR 10 SECONDS AT 260°C.
 - WATER PROOFNESS: THIS PRODUCT IS BASED ON IPX7.

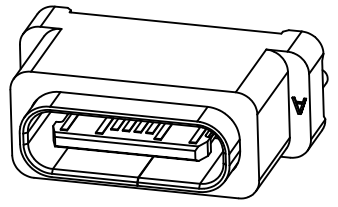
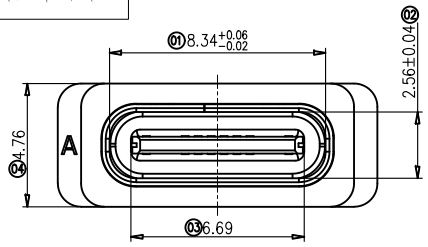
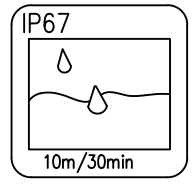
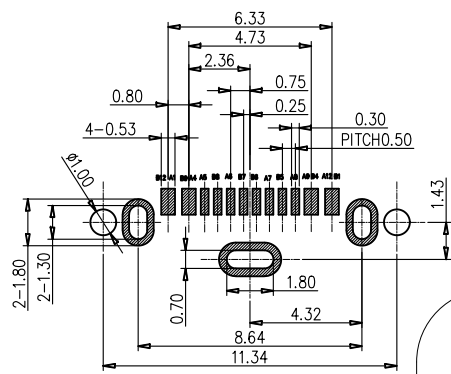
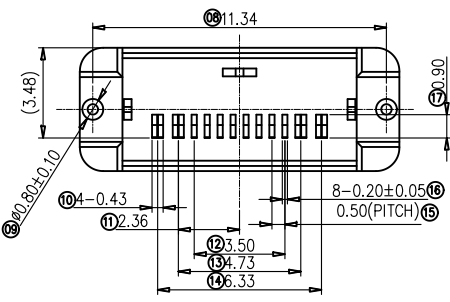

A1	GND	B12	GND
A4	VBUS	B9	VBUS
A5	CC1	B8	SBU2
A6	DP1	B7	DN2
A7	DN1	B6	DP2
A8	SBU1	B5	CC2
A9	VBUS	B4	VBUS
A12	GND	B1	GND
PIN	SIGNAL NAME	PIN	SIGNAL NAME

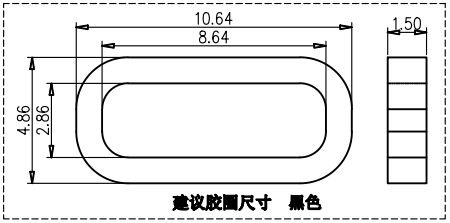

MILLIMETERS	INCH
X.° ±2°	X.° ±2°
.X ±0.30	.X ±0.012
.XX ±0.20	.XX ±0.008
.XXX ±0.10	.XXX ±0.004



FOR YOUR VITAL CONNECTION

TITLE: USB3.2TYPE C 母座 24PIN 防水 沉板双SMT 斜口CH0.4 IP68

DRAWN BY:	Zou Long	PART NO:	UC368752E1	SHEET:	1 OF 3	REV:	A0
CHECKED BY:	Bob	DWG NO:	VTC-TZ-00141	SIZE:	A4	UNIT:	mm
FCN:	E1						

For technical support, please send an email to support@vitalconn.com

APPROVED BY:	QPF	PROJECTION:		http://www.vitalconn.com
--------------	-----	-------------	--	--------------------------



REV:	ECN. NO.	NAME	DATE
A0	----	-----	04-28-2026

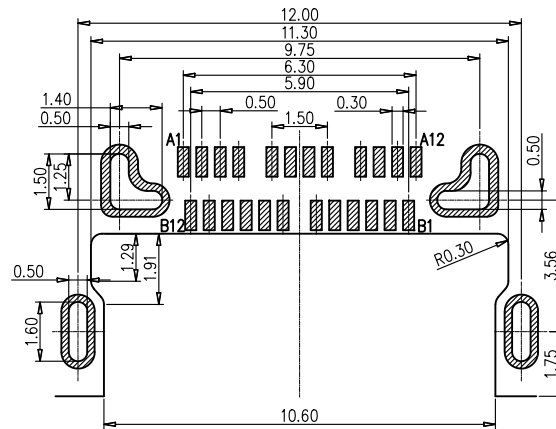
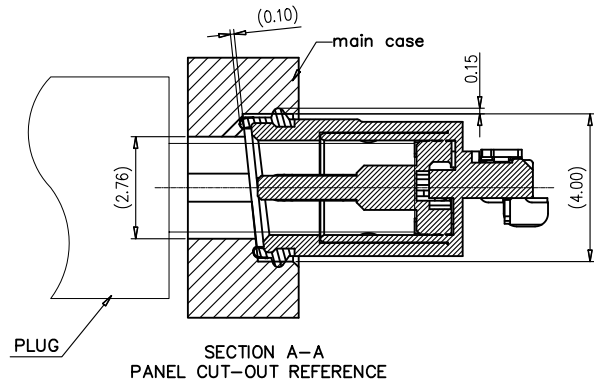
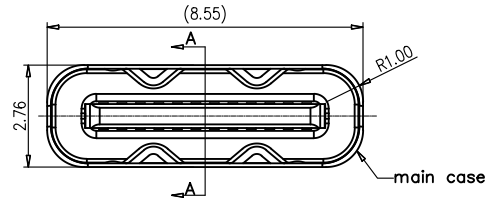

RECOMMENDED PCB LAYOUT
TOLERANCE=±0.05

- NOTES:
- MATERIAL:
 - MAIN HOUSING: PA46 UL94V-0; COLOR: BLACK
 - LIM: 硅胶 BALCK
 - SHELL HOUSING: PA46 UL94V-0; COLOR: BLACK
 - SOLDER PIN: SUS304
 - SHELL: SUS304
 - TERMINAL: C18400
 - MID PLATE: SUS301
 - FINISH:
 - TERMINAL: Au 15u" MIN. PLATED ON CONTACT AREA; G/F PLATED ON SOLDER AREA; Ni 30u" MIN. UNDERPLATED OVERALL.
 - SHELL/SOLDER PIN: Ni 30u" MIN. PLATED OVERALL.
 - MID PLATE: Ni 30u" MIN. PLATED OVERALL.
 - ELECTRICAL SPECIFICATION:
 - RATED CURRENT: VBUS AND GND PIN 5A; Other pin 0.25A
 - CONTACT RESISTANCE: 40mΩ MAX(INITIAL). 50mΩ MAX (AFTER).
 - INSULATION RESISTANCE: 100MΩ MIN.
 - DIELECTRIC WITHSTANDING VOLTAGE: 100V AC
 - MACHINERY SPECIFICATION:
 - MATING FORCE: 5N~20N. UNMATING FORCE: 8N~20N. (AFTER TEST:6N~20N).
 - DURABILITY: 10000 CYCLES MIN.
 - ENVIRONMENTAL SPECIFICATION
 - OPERATING CONDITION: TEMPERATURE-40°C~+85°C; HUMIDITY 80% R.H MAX
 - SALT SPRAY: 24H
 - SOLDER ABILITY: 245±5°C, 5±0.5s
 - IR REFLOW: THE PEAK TEMPERATURE ON THE BOARD SHALL BE MAINTAINED FOR 10 SECONDS AT 260°C.
 - After removing the vacuum packaging and need to be completed SMT within 8 hours.
- △(拆除真空包装后, 需要在8小时内完成贴片。)

MILLIMETERS	INCH
X.° ±2°	X.° ±2°
.X ±0.30	.X ±0.012
.XX ±0.20	.XX ±0.008
.XXX ±0.10	.XXX ±0.004



FOR YOUR
VITAL CONNECTION

TITLE: USB3.2TYPE C 母座 24PIN 防水 沉板双SMT 斜口CH0.4 IP68

DRAWN BY:	Zou Long	PART NO:	UC368752E1	SHEET:	2 OF 3	REV:	A0		
CHECKED BY:	Bob	DWG NO:	VTC-TZ-00141	SIZE:	A4	UNIT:	mm	FCN:	E1
APPROVED BY:	QPF	PROJECTION:		http://www.vitalconn.com					

For technical support, please send an email to support@vitalconn.com



REV:	ECN. NO.	NAME	DATE
A0	----	-----	04-28-2026

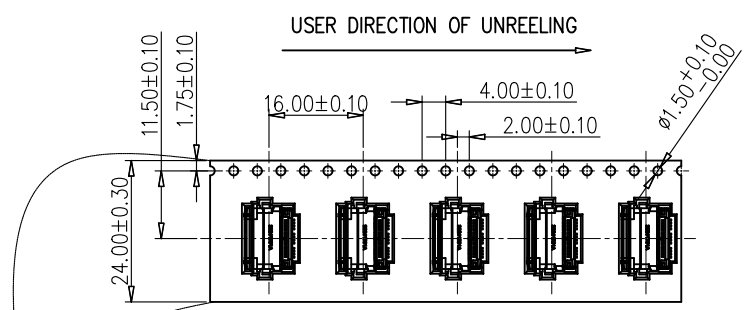

NOTES

1. NUMBER OF CONNECTORS: 800PCS/REEL
2. LEAD TAPE LENGTH

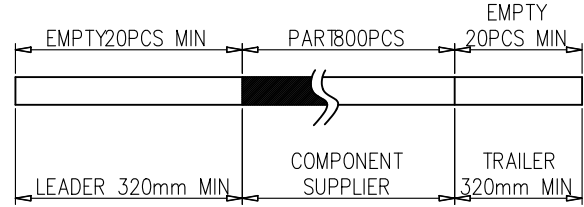

3. QUANTITY: 8800PCS/CARTON

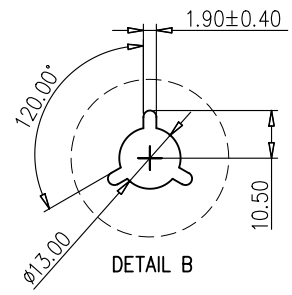
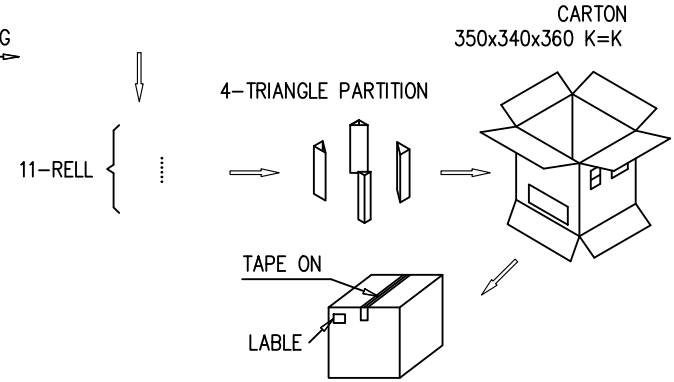
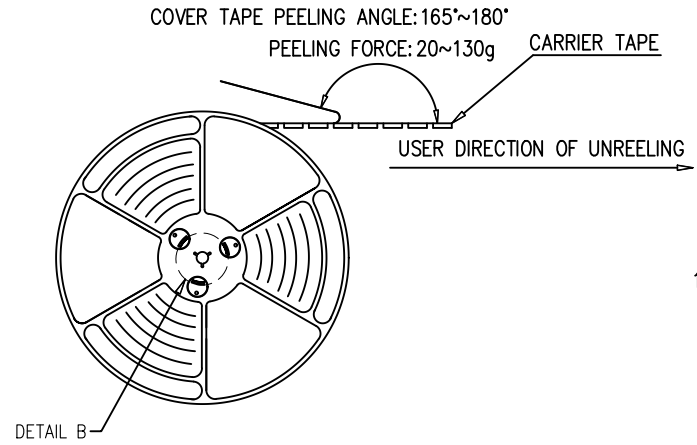

MILLIMETERS	INCH
X.° ±2°	X.° ±2°
.X ±0.30	.X ±0.012
.XX ±0.20	.XX ±0.008
.XXX ±0.10	.XXX ±0.004



FOR YOUR VITAL CONNECTION

TITLE: USB3.2TYPE C 母座 24PIN 防水 沉板双SMT 斜口CH0.4 IP68

DRAWN BY:	Zou Long	PART NO:	UC368752E1	SHEET:	3 OF 3	REV:	A0
CHECKED BY:	Bob	DWG NO:	VTC-TZ-00141	SIZE:	A4	UNIT:	mm
APPROVED BY:	QPF	PROJECTION:		http://www.vitalconn.com			

For technical support, please send an email to support@vitalconn.com