

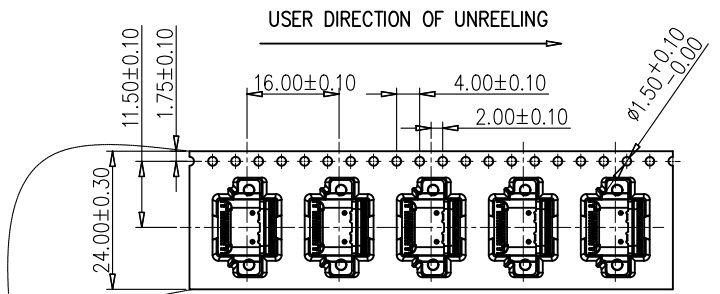



REV:	ECN. NO.	NAME	DATE
A0	-----	-----	04-28-2026



NOTES

1. NUMBER OF CONNECTORS: 900PCS/REEL
2. LEAD TAPE LENGTH

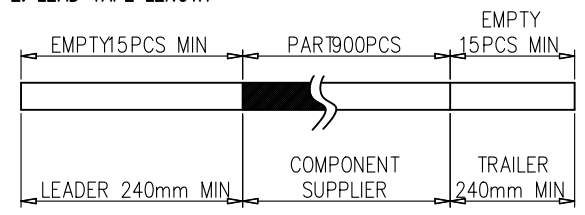

3. QUANTITY: 9000PCS/CARTON

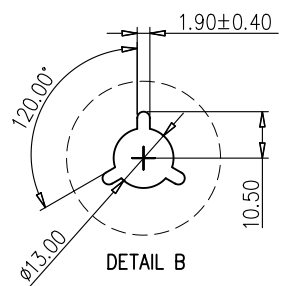
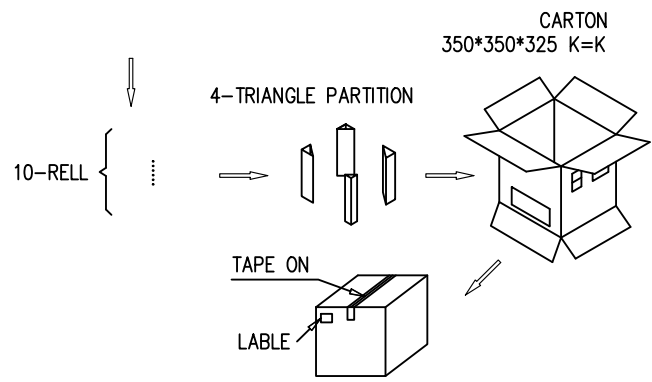
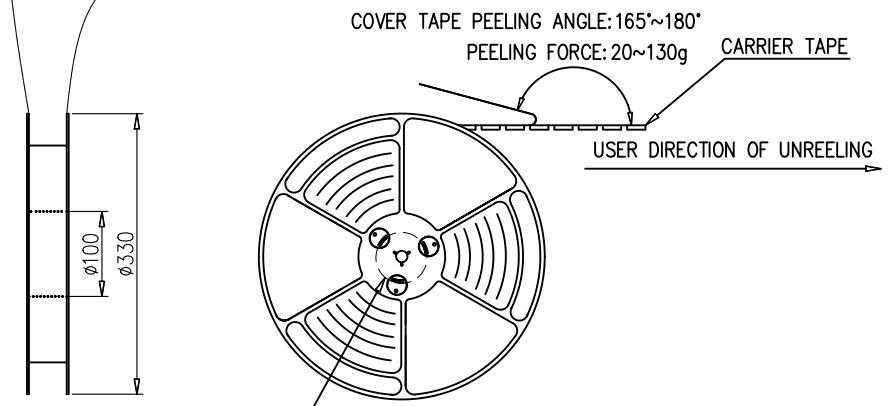

MILLIMETERS	INCH
X.° ±2°	X.° ±2°
.X ±0.30	.X ±0.012
.XX ±0.20	.XX ±0.008
.XXX ±0.10	.XXX ±0.004



FOR YOUR VITAL CONNECTION

TITLE:	TYPE C 24PIN 双壳沉板0.88 双排SMT								
DRAWN BY:	Zou Long	PART NO:	UC369702E1	SHEET:	2 OF 2	REV:	A0		
CHECKED BY:	Bob	DWG NO:	VTC-TZ-00142	SIZE:	A4	UNIT:	mm	FCN:	E1
APPROVED BY:	QPF	PROJECTION:		<a href="http://www.vitalconn.com">http://www.vitalconn.com</a>					

For technical support, please send an email to [support@vitalconn.com](mailto:support@vitalconn.com)