

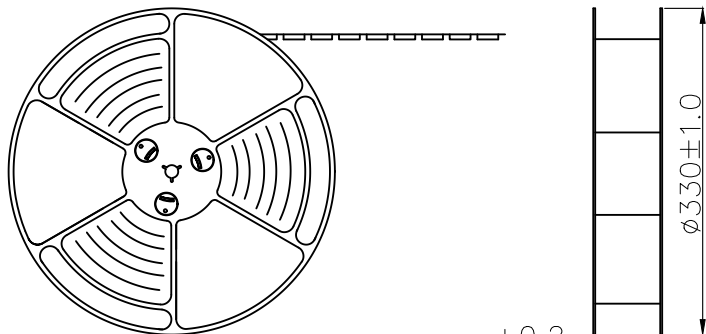

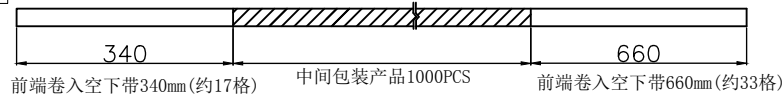

载带收料方向



出料方向  
PULL OUT DIRECTEON

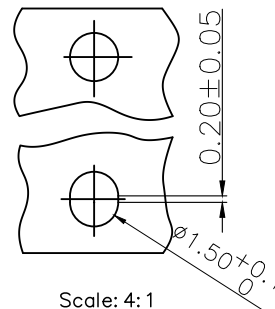
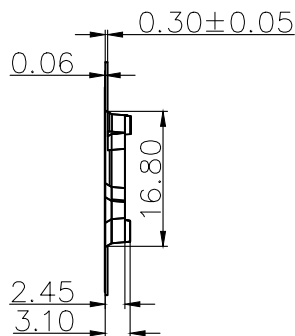
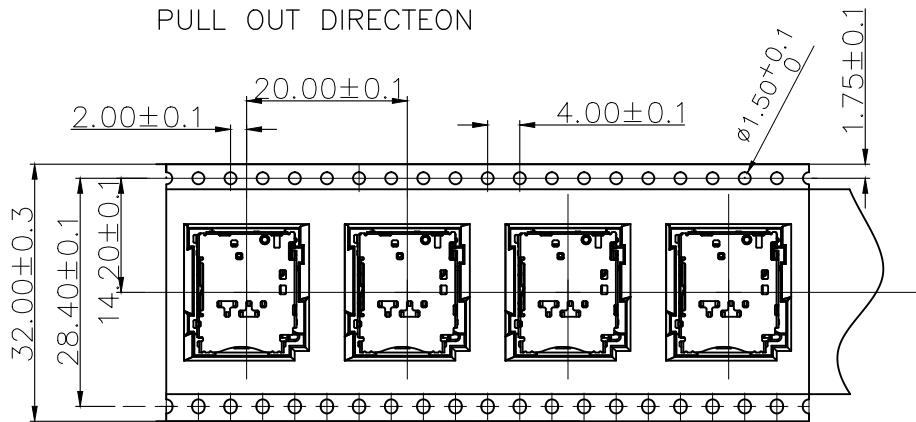

Scale: 4:1

标签粘贴处 (朝卷装包材 椭圆 定位孔一侧)

Location of label sticking (label at positioning hole of the carrier tape side).

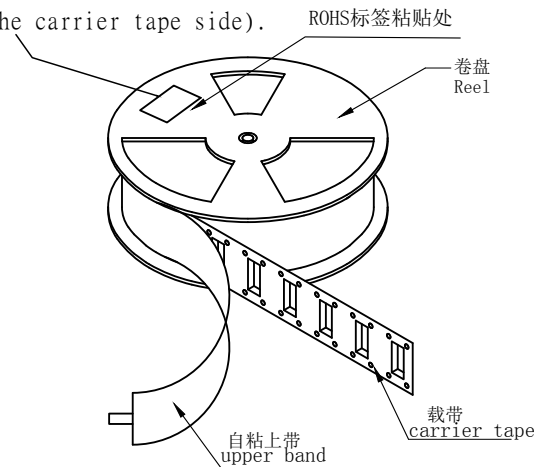

自粘上带 upper band

卷盘 Reel

载带 carrier tape

1.50 ± 0.1

0.20 ± 0.05

|                              |           |
|------------------------------|-----------|
| DIMENSIONS IN: mm            |           |
| UNLESS OTHERWISE SPECIFIABLE |           |
| DIMENSION                    | TOLERANCE |
| X.X:                         | ±0.35     |
| X.XX:                        | ±0.25     |
| X.XXX:                       | ±0.10     |
| ANGULAR:                     | ± 2°      |



FOR YOUR VITAL CONNECTION

TITLE:

NANO SIM H1.50 CARD

|              |          |             |                 |   |        |       |    |
|--------------|----------|-------------|-----------------|---|--------|-------|----|
| DRAWN BY:    | Zou Long | PART NO:    | CT113115018E7   | SHEET:  | 2 OF 3 | REV:  | A0 |
| CHECKED BY:  | Bob      | DWG NO:     | D-CT113115018E7 | SIZE:   | A4     | UNIT: | mm |
| APPROVED BY: | QPF      | PROJECTION: |                 | <a href="http://www.vitalconn.com">http://www.vitalconn.com</a> |        |       |    |

For technical support, please send an email to [support@vitalconn.com](mailto:support@vitalconn.com)



|      |          |       |            |
|------|----------|-------|------------|
| REV: | ECN. NO. | NAME  | DATE       |
| A0   | -----    | ----- | 04-07-2026 |

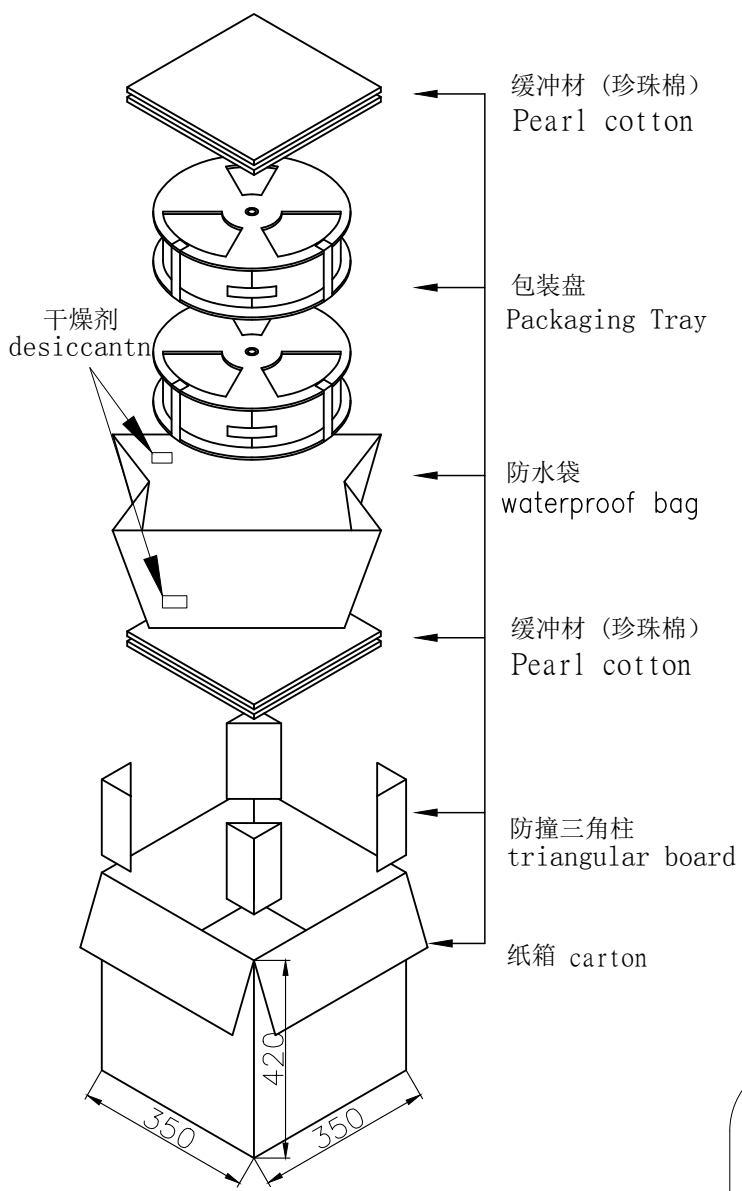

|    |                        |          |
|----|------------------------|----------|
| 10 | 干燥剂(desiccantn)        | 2PCS     |
| 9  | 三角纸板(triangular board) | 4PCS     |
| 8  | 珍珠棉(Pearl cotton)      | 4PCS     |
| 7  | 纸箱(carton)             | 1PCS     |
| 6  | 保护带(bracer)            | 10PCS    |
| 5  | 自粘上带(Cover tape)       | 21.0M*10 |
| 4  | 卷盘(reeel)              | 10PCS    |
| 3  | PE防水袋(waterproof bag)  | 1PCS     |
| 2  | 载带(carrier tape)       | 10PCS    |
| 1  | NANO SIM H1.5 CARD     | 10000PCS |

- 备注:
- 每卷载带前端卷入空下带17PCS, 尾端卷入空下带33PCS.  
1. Each volume loading front into empty with 17 PCS, with 33PCS under the end in empty
  - 每卷载带包装1000PCS 产品。  
2. Each volume loading packing 1000 PCS products
  - 以自粘上带覆盖经包装机冷封包装。  
3. With adhesive on the belt cover after packing machine cold sealing packing
  - 以保护带覆盖于外圈再以胶带固定并粘贴卷盘标签 (标签位置可依客户要求)  
4. Covered with safety belt in the outer ring, Then mounted label with adhesive tape (Location can be in accordance with the customer)
  - 将10卷包装好的产品放入PE防水袋, 防水袋的上下各放置2PCS珍珠棉, 以胶带固定PE防水袋。  
5. Will 10 products in a waterproof bag. The upper place 2 PCS pearl cotton, Adhesive plaster waterproof PE bag
  - 将包装好的10卷产品放入纸箱, 四周用三角压线条固定; 外箱用胶带呈“工”字形封口。  
6. The packaged products 10 rolls into the cartons. All round with triangle board, Outside the box sealed with adhesive tape.
  - 外箱标签的贴法请参照客户资料。  
7. Carton label reference customer data.
  - 零件必须符合TAISOL HF WD-3-I-091规范。  
8. Part must comply TAISOL HF WD-3-I-091 specification.

|                              |           |
|------------------------------|-----------|
| DIMENSIONS IN: mm            |           |
| UNLESS OTHERWISE SPECIFIABLE |           |
| DIMENSION                    | TOLERANCE |
| X. X:                        | ±0.35     |
| X. XX:                       | ±0.25     |
| X. XXX:                      | ±0.10     |
| ANGULAR:                     | ± 2°      |



FOR YOUR VITAL CONNECTION

|              |          |                     |                 |                          |        |       |    |      |    |
|--------------|----------|---------------------|-----------------|--------------------------|--------|-------|----|------|----|
| TITLE:       |          | NANO SIM H1.50 CARD |                 |                          |        |       |    |      |    |
| DRAWN BY:    | Zou Long | PART NO:            | CT113115018E7   | SHEET:                   | 3 OF 3 | REV:  | A0 |      |    |
| CHECKED BY:  | Bob      | DWG NO:             | D-CT113115018E7 | SIZE:                    | A4     | UNIT: | mm | FCN: | E7 |
| APPROVED BY: | QPF      | PROJECTION:         |                 | http://www.vitalconn.com |        |       |    |      |    |

For technical support, please send an email to support@vitalconn.com