

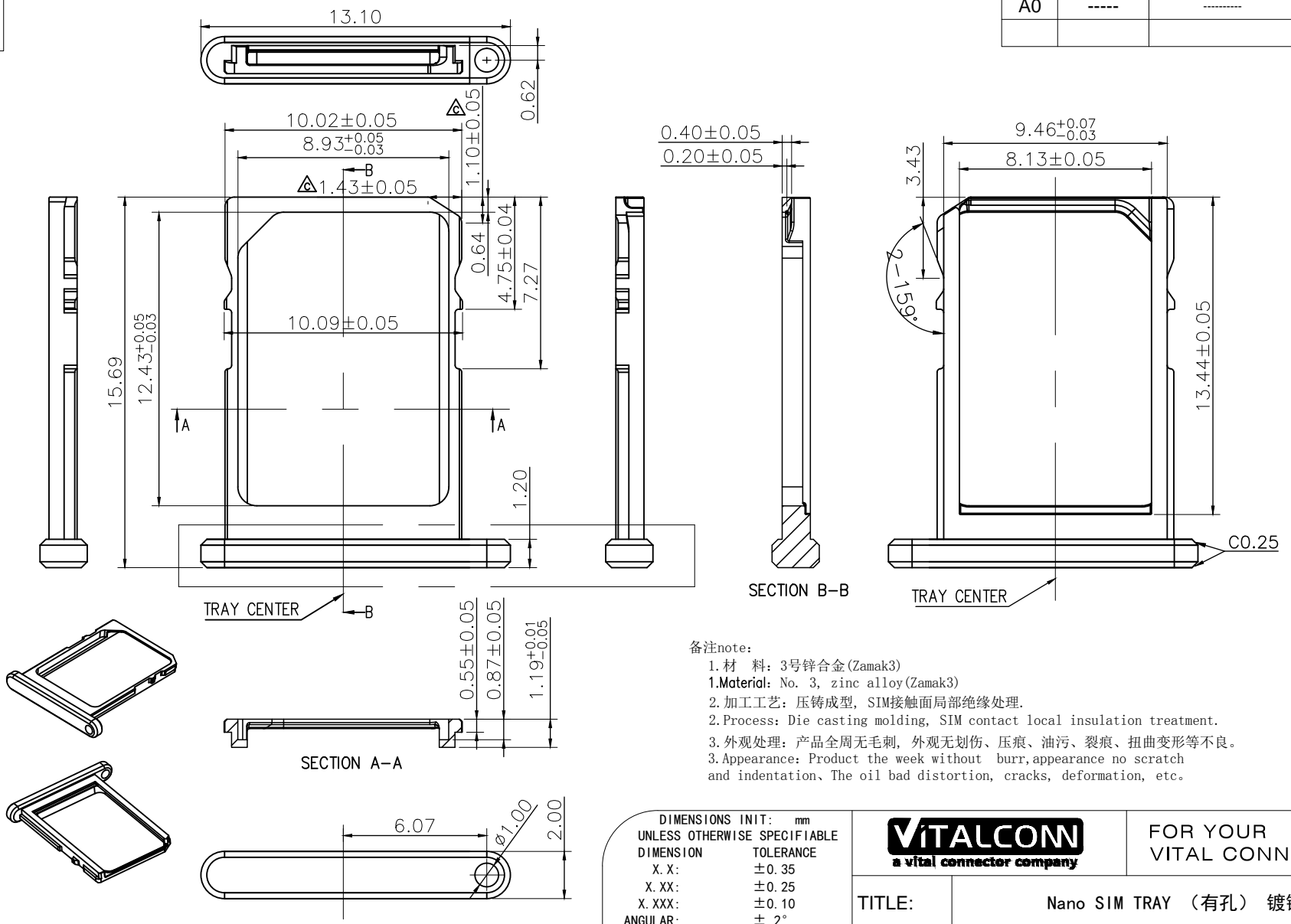

7		8	
REV:	ECN. NO.	NAME	DATE
A0	-----	-----	04-07-2026



- 备注note:
1. 材料: 3号锌合金 (Zamak3)
1. Material: No. 3, zinc alloy (Zamak3)
 2. 加工工艺: 压铸成型, SIM接触面局部绝缘处理。
2. Process: Die casting molding, SIM contact local insulation treatment.
 3. 外观处理: 产品全周无毛刺, 外观无划伤、压痕、油污、裂痕、扭曲变形等不良。
3. Appearance: Product the week without burr, appearance no scratch and indentation, The oil bad distortion, cracks, deformation, etc.

DIMENSIONS IN IT: mm UNLESS OTHERWISE SPECIFIABLE		 a vital connector company		FOR YOUR VITAL CONNECTION	
DIMENSION	TOLERANCE				
X.X:	±0.35	TITLE: Nano SIM TRAY (有孔) 镀镍			
X.XX:	±0.25	DRAWN BY: Zou Long	PART NO: CZ0000KT01E7	SHEET: 1 OF 1	REV: A0
X.XXX:	±0.10	CHECKED BY: Bob	DWG NO: D-CZ0000KT01E7	SIZE: A4	UNIT:mm
ANGULAR:	± 2°	APPROVED BY: QPF	PROJECTION:	http://www.vitalconn.com	

For technical support, please send an email to support@vitalconn.com



REV:	ECN. NO.	NAME	DATE
A0	-----	-----	04-07-2026

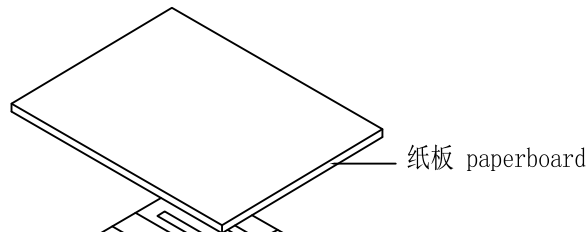

纸板 paperboard

每40盘叠一沓，顶部叠一空盘作上盖，再用PE膜缠绕。
Every 40 plate fold a stack, at the top of the stack Empty plate on the cover, then use PE film winding.

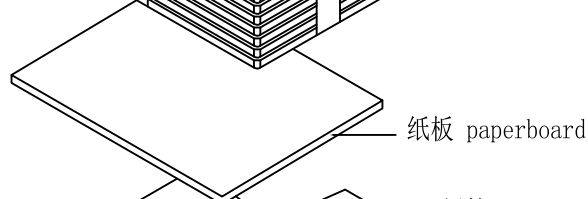
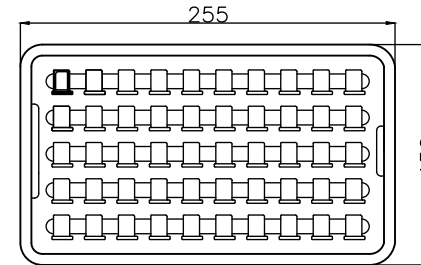

纸板 paperboard

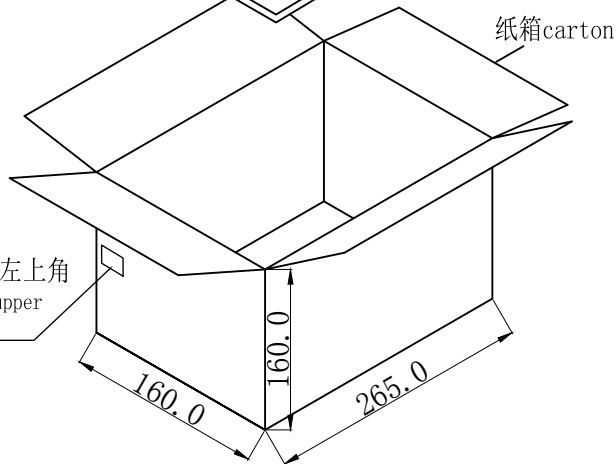

纸箱 carton

外箱标签贴在左上角
Labels in the upper left corner

备注:

- 数量: 50PCS/盘*40盘/箱=2000PCS/箱.
1:Quantity: 50 PCS/disc * 40 plate/box = 2000 PCS/box.
- 外箱规格(内径): 265*160*160mm.
2. Carton size (diameter) : 265 * 160 * 160 mm
- 产品务必照图面规定方向放置, 且吸塑盒层叠方向一致。
3. Products must be placed according to the drawings by the multilayer and blister box of cascade in the same direction
- 零数箱必须以缓冲材塞满
4. Must to cushion material with a null box
- 用TRAY将纸箱封实。
5. The carton seal with TAPE.
- 外箱标签贴在左上角。
6. Carton label in the upper left corner.
- 零件必须符合TAISOL HF WD-3-I-091规范。
7. Part must comply TAISOL HF WD-3-I-091 specification.

DIMENSIONS INIT: mm	
UNLESS OTHERWISE SPECIFIABLE	
DIMENSION	TOLERANCE
X. X:	±0.35
X. XX:	±0.25
X. XXX:	±0.10
ANGULAR:	± 2°



FOR YOUR VITAL CONNECTION

TITLE: Nano SIM TRAY (有孔) 镀镍

DRAWN BY:	Zou Long	PART NO:	CZ0000KT01E7	SHEET:	2 OF 2	REV:	A0
CHECKED BY:	Bob	DWG NO:	D-CZ0000KT01E7	SIZE:	A4	UNIT:	mm
APPROVED BY:	QPF	PROJECTION:		http://www.vitalconn.com			

For technical support, please send an email to support@vitalconn.com