



REV:	ECN. NO.	NAME	DATE
A0	-----	-----	04-07-2026

Specification

1.MATERIAL:

- 1.1 Insulator: High Temperature Thermoplastic, LCP SZ6505HF black UL94V-0.
- 1.2 Terminal: Phosphor Bronze(C5210-H, T=0.15mm)
- 1.3 Shell: SUS301-3/4H T=0.10mm
- 1.4 Spring: SUS301 L=9.80mm
- 1.5 Slider: PA9T black
- 1.6 Drawbar: SUS304-H,L=3.85mm

2.Plating:

- 2.1 Terminal: Plated 80u"min Ni Overall
Plated 1u"min Au Selective contact area
Plated 1u"min AU over Ni on solder area
- 2.2 Shell: Plated 1u"min AU overll 50u"min Ni

3.Property:

- 3.1 Current Rating :0.5A AC/DC max.
- 3.2 Voltage Rating :12V AC/DC
- 3.3 Ambient Temperature Range :-25°C~+85°C
- 3.4 Ambient Humidity Range :95% R.H. Max.
- 3.5 Contact Resistance:100mΩ max.
- 3.6 Insulation Resistance:1000MΩ min./500VDC
- 3.7 Durability:5000 cycles

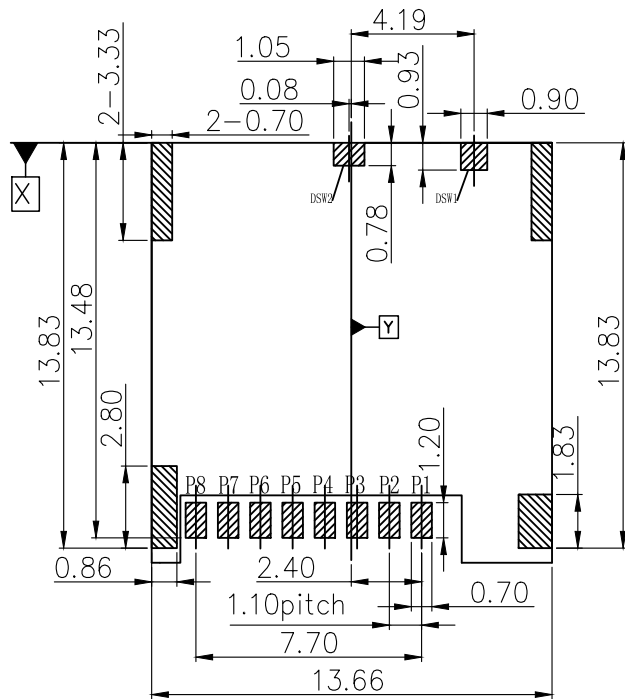

RECOMMEND P.C.B LAYOUT
(General tolerance ± 0.05)

- PAD AREA
- KEEP OUT AREA
- GND PATTERN ONLY

PIN NO.	PIN ASSIGNMENT
P1	DAT2
P2	CD/DAT3
P3	CMD
P4	VDD
P5	CLK
P6	VSS
P7	DAT0
P8	DAT1

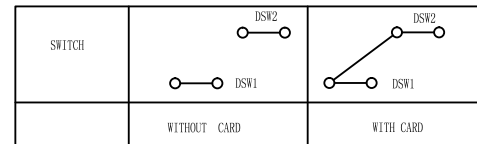

DIMENSIONS INIT: mm
UNLESS OTHERWISE SPECIFIABLE
DIMENSION TOLERANCE
X.X: ± 0.35
X.XX: ± 0.25
X.XXX: ± 0.10
ANGULAR: $\pm 2^\circ$

VITALCON
a vital connector company

FOR YOUR
VITAL CONNECTION

TITLE: Micro-SD H1.28 CARD

For technical support, please send an email to support@vitalconn.com

DRAWN BY:	Zou Long	PART NO:	CT115112802E7	SHEET:	2 OF 4	REV:	A0
CHECKED BY:	Bob	DWG NO:	D-CT115112802E7	SIZE:	A4	UNIT:	mm
APPROVED BY:	QPF	PROJECTION:		http://www.vitalconn.com			



REV:	ECN. NO.	NAME	DATE
A0	-----	-----	04-07-2026

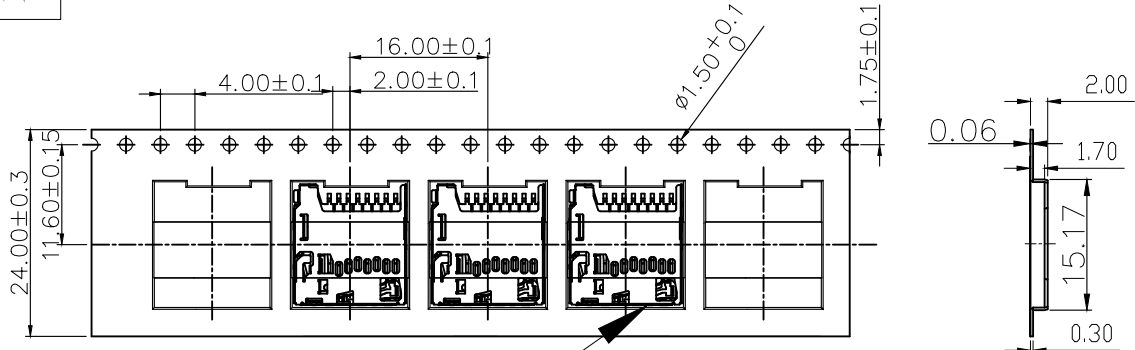

產品放置方向

PULL OUT DIRECTION →

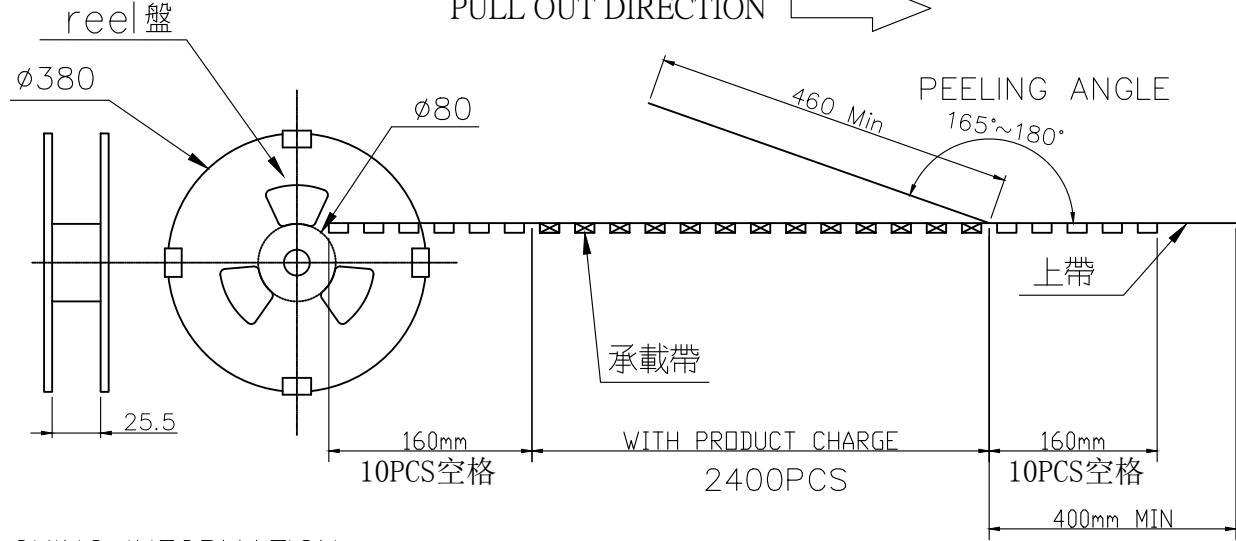
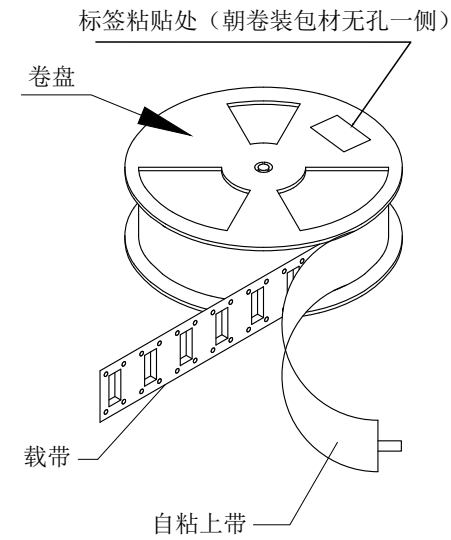

PACKING INFORMATION

PART NAME	Micro SD H1.28 CARD包装规范
QUANTITY OF PER TRAY	2400PCS/TRAY
QUANTITY OF PER CARTON	7*2400=16800PCS/CARTON

DIMENSIONS INIT: mm
 UNLESS OTHERWISE SPECIFIABLE
 DIMENSION TOLERANCE
 X.X: ±0.35
 X.XX: ±0.25
 X.XXX: ±0.10
 ANGULAR: ± 2°



FOR YOUR VITAL CONNECTION

TITLE:	Micro-SD H1.28 CARD								
DRAWN BY:	Zou Long	PART NO:	CT115112802E7	SHEET:	3 OF 4	REV:	A0		
CHECKED BY:	Bob	DWG NO:	D-CT115112802E7	SIZE:	A4	UNIT:	mm	FCN:	E7
APPROVED BY:	QPF	PROJECTION:		http://www.vitalconn.com					

For technical support, please send an email to support@vitalconn.com



REV:	ECN. NO.	NAME	DATE
A0	-----	-----	04-07-2026

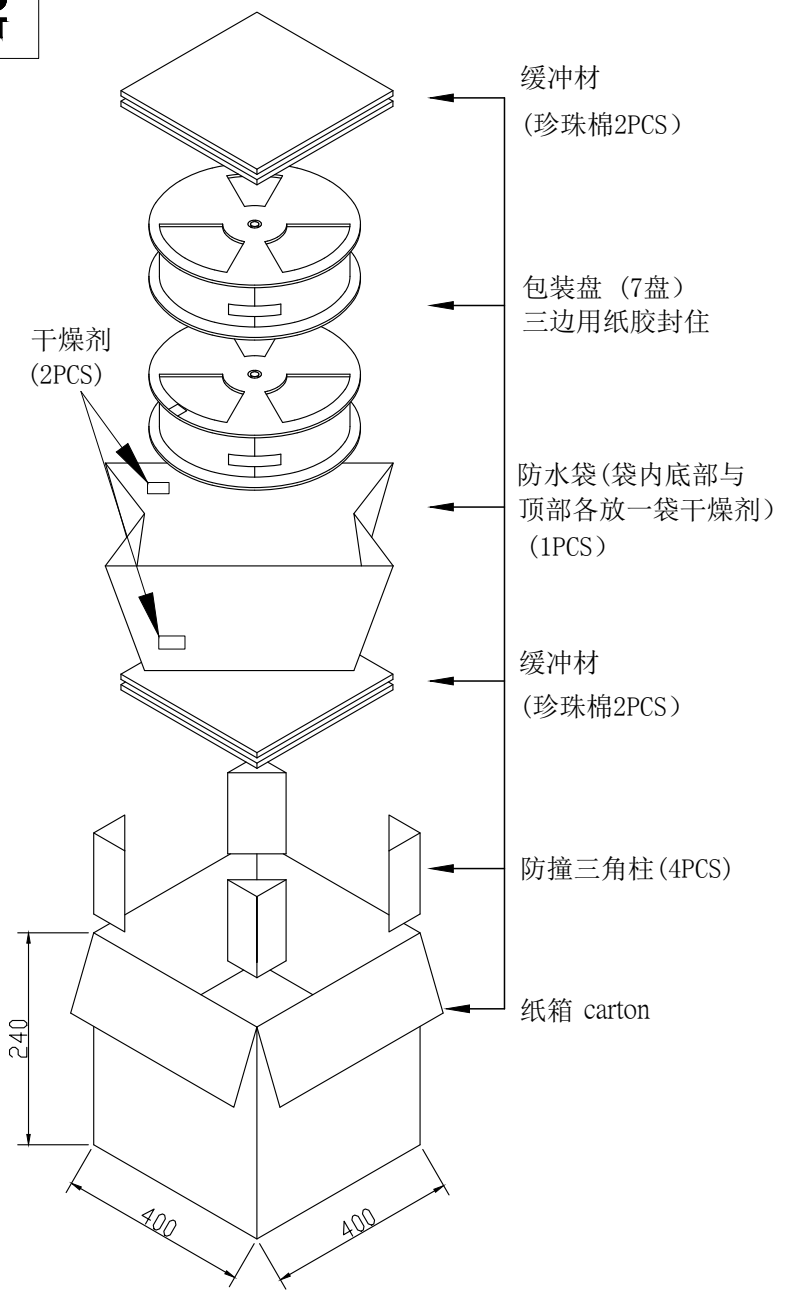

10	干燥剂	2PCS
9	三角压线条	4PCS
8	珍珠棉	4PCS
7	纸箱	1PCS
6	保护带	7PCS
5	自粘上带	38.72M*7
4	卷盘	7PCS
3	PE防水袋	1PCS
2	载带	7pcs
1	Micro SD H1.28 CARD	16800PCS

备注:

1. 每卷载带前后各留10个空格不使用.
2. 每卷载带包装2400PCS产品 .
3. 以自粘上带覆盖经包装机冷封包装.
4. 以保护带覆盖于外圈再以胶带固定并粘贴卷盘标签.
5. 将7卷包装好的产品放入PE防水袋, 防水袋的上下各放置2PCS珍珠棉, 以胶带固定PE防水袋.
6. 将包装好的7卷产品放入纸箱, 四周用三角压线条固定; 外箱用胶带呈“工”字形封口.
7. 外箱标签的贴法请参照客户资料.

DIMENSIONS INIT: mm	
UNLESS OTHERWISE SPECIFIABLE	
DIMENSION	TOLERANCE
X. X:	±0.35
X. XX:	±0.25
X. XXX:	±0.10
ANGULAR:	± 2°



FOR YOUR VITAL CONNECTION

TITLE: Micro-SD H1.28 CARD			
DRAWN BY: Zou Long	PART NO: CT115112802E7	SHEET: 4 OF 4	REV: A0
CHECKED BY: Bob	DWG NO: D-CT115112802E7	SIZE: A4	UNIT:mm FCN: E7
APPROVED BY: QPF	PROJECTION:	http://www.vitalconn.com	

For technical support, please send an email to support@vitalconn.com