

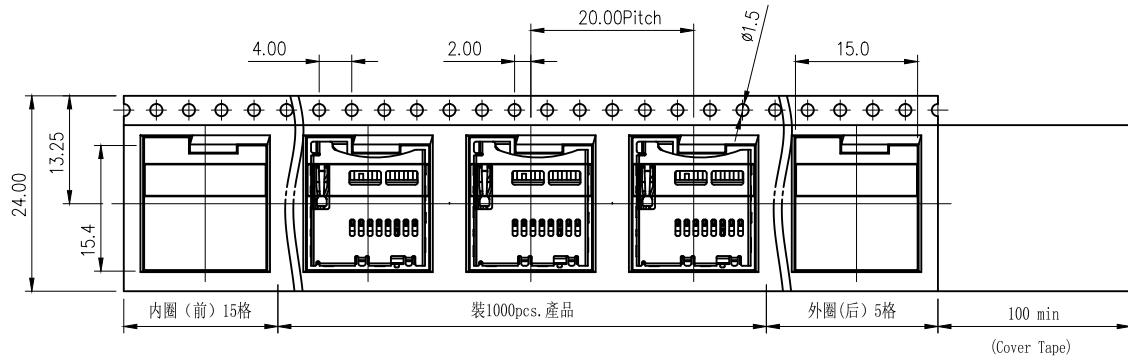



7		8	
REV: A0	ECN. NO.: -----	NAME: -----	DATE: 04-07-2026



PULL OUT DIRECTION →

出料方向  
PULL OUT DIRECTEON →

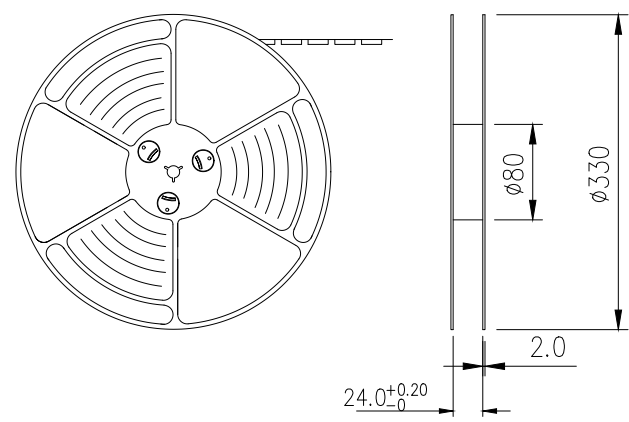
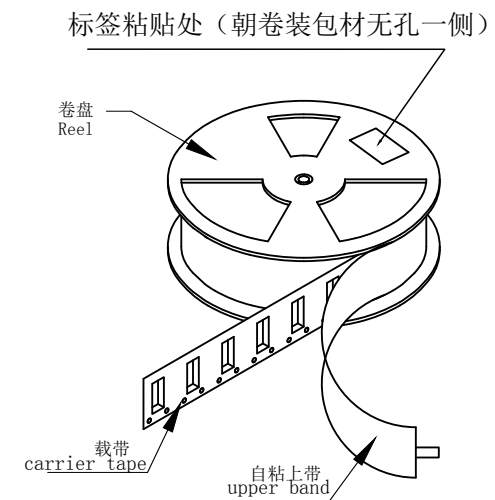

DIMENSIONS INIT: mm	
UNLESS OTHERWISE SPECIFIABLE	
DIMENSION	TOLERANCE
X. X:	±0.35
X. XX:	±0.25
X. XXX:	±0.10
ANGULAR:	± 2°



FOR YOUR VITAL CONNECTION

TITLE: MICRO SD P-P H1.95 内焊无柱			
DRAWN BY: Zou Long	PART NO: CT125119501WE7	SHEET: 2 OF 3	REV: A0
CHECKED BY: Bob	DWG NO: D-CT125119501WE7	SIZE: A4	UNIT:mm FCN: E7
APPROVED BY: QPF	PROJECTION:	http://www.vitalconn.com	

For technical support, please send an email to support@vitalconn.com



REV:	ECN. NO.	NAME	DATE
A0	-----	-----	04-07-2026

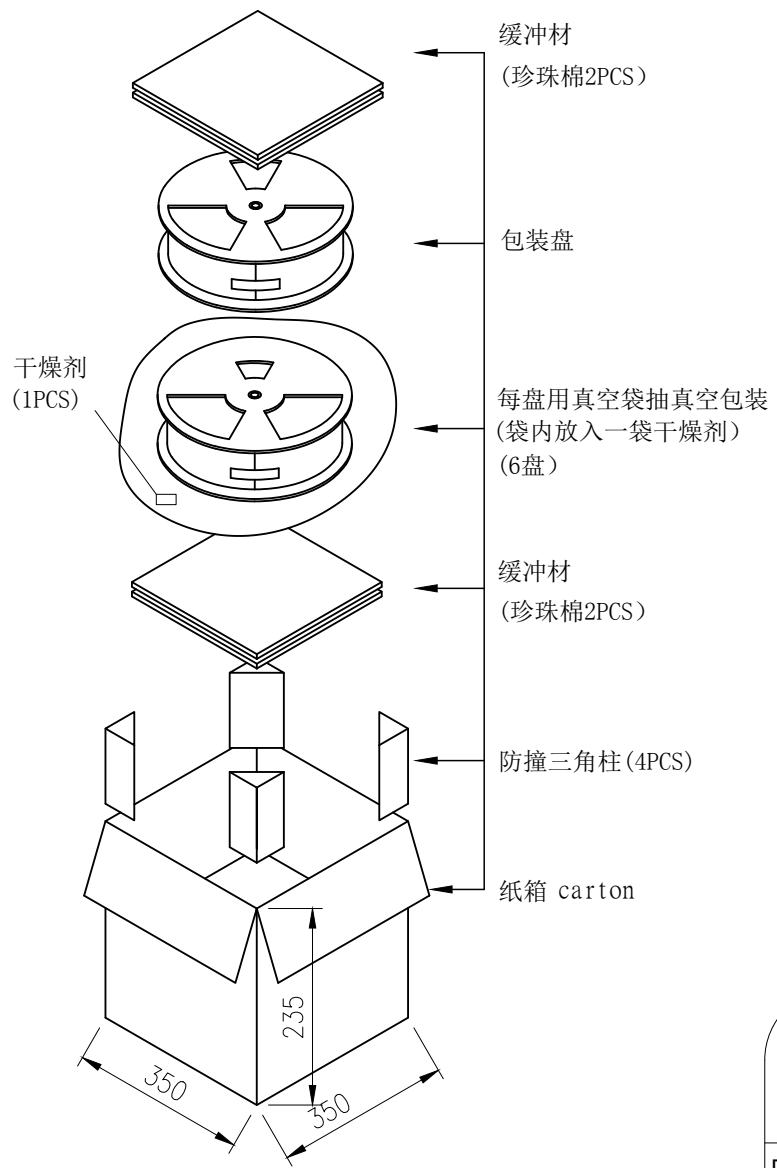

11	真空袋 (vacuum bag)	6PCS
10	干燥剂 (desiccantn)	6PCS
9	三角纸板 (triangular board)	4PCS
8	珍珠棉 (Pearl cotton)	4PCS
7	纸箱 (carton)	1PCS
6	保护带 (bracer)	6PCS
5	自粘上带 (Cover tape)	24.2M*6
4	卷盘 (reel)	6PCS
3	PE防水袋 (waterproof bag)	1PCS
2	载带 (carrier tape)	24M*6
1	Micro SD H1.95 C onn.	6000PCS

备注:

1. 每卷内圈(前)空留空载带15PCS, 外圈(后)空留空载带5PCS.
2. 每卷载带包装1000PCS产品 .
3. 以自粘上带覆盖经包装机冷封包装.
4. 以保护带覆盖于外圈再以胶带固定并粘贴卷盘标签.
5. 将包装好的产品放入真空袋, 袋内放入一包干燥剂, 抽真空包装.
6. 将包装好的6卷产品放入纸箱, 四周用三角压线条固定, 上下各放置2PCS珍珠棉, 外箱用胶带呈“工”字形封口.
7. 外箱标签的贴法请参照客户资料.

DIMENSIONS INIT: mm	
UNLESS OTHERWISE SPECIFIABLE	
DIMENSION	TOLERANCE
X. X:	±0.35
X. XX:	±0.25
X. XXX:	±0.10
ANGULAR:	± 2°



FOR YOUR VITAL CONNECTION

TITLE:	MICRO SD P-P H1.95 内焊无柱								
DRAWN BY:	Zou Long	PART NO:	CT125119501WE7	SHEET:	3 OF 3	REV:	A0		
CHECKED BY:	Bob	DWG NO:	D-CT125119501WE7	SIZE:	A4	UNIT:	mm	FCN:	E7
APPROVED BY:	QPF	PROJECTION:		<a href="http://www.vitalconn.com">http://www.vitalconn.com</a>					

For technical support, please send an email to [support@vitalconn.com](mailto:support@vitalconn.com)