

REV:	ECN. NO.	NAME	DATE

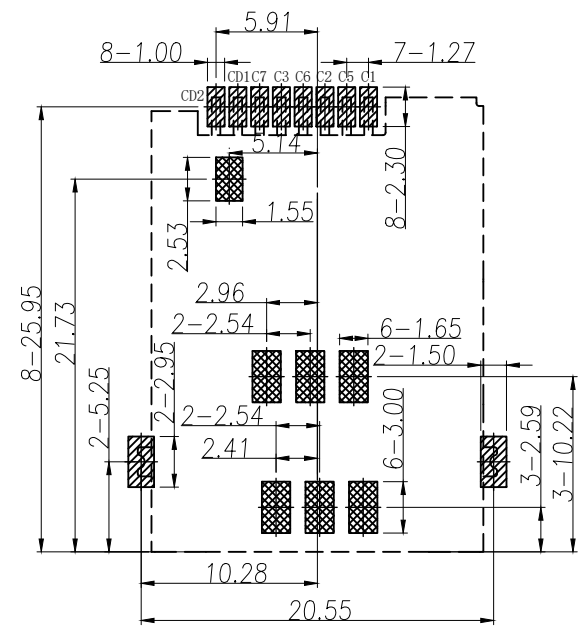
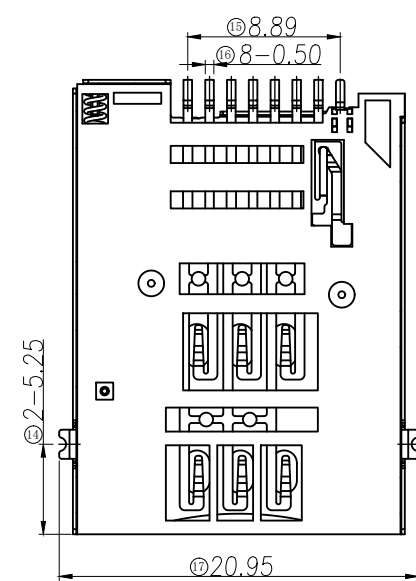
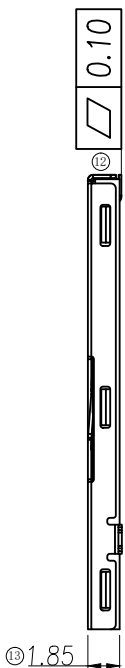
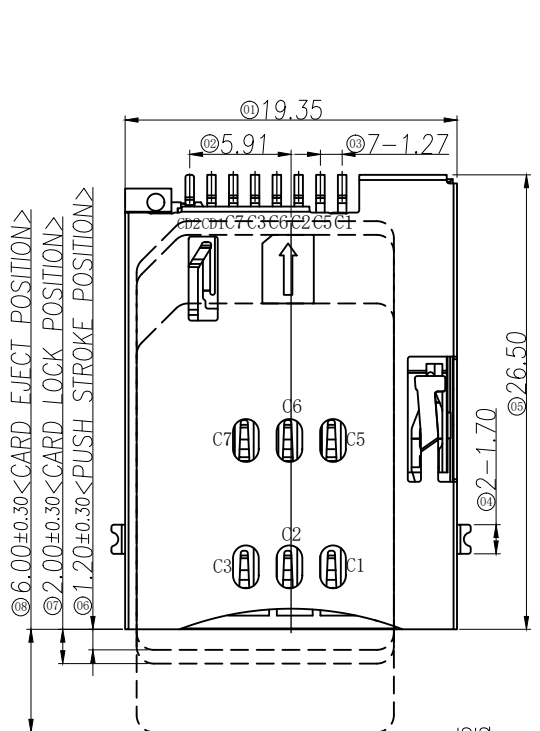

RECOMMENDED PCB LAYOUT

TOLERANCE: ±0.05

- SMT SOLDER AREA
- COPPER RESTRICTED AREA
- 1. TOUCH AREA OF CONTACT
- TIPS NO ELECTRICAL FUNCTION
- 2. NO FIRST PCB\_LAYOUT
- CIRCUITS IN THE AREA

Specification  
 Material  
 Plastic Housing: LCP 30%GF. UL94V-0, Black  
 Contact Terminal: Phosphor Bronze, T=0.15mm  
 Cover: SUS304, T=0.2mm

Plating:  
 Contact Terminal  
 Contact Area: Gold Flash  
 Solder area: Tin 80u" min.  
 Underplating: Ni overall 50u" min.  
 Cover: Ni overall 30u" min.  
 Solder area: Gold Flash

Electrical  
 Voltage Rating: 30V max.  
 Current Rating: 0.5A max.  
 Dielectric Withstanding Voltage: 100V AC (60 Sec min.)  
 Insulation Resistance: 1000 MΩ min.  
 Contact Resistance: 100 mΩ max.

Mechanical & Environmental  
 Operating Temperature: -40°C to +85°C  
 Durability: 5000 cycles

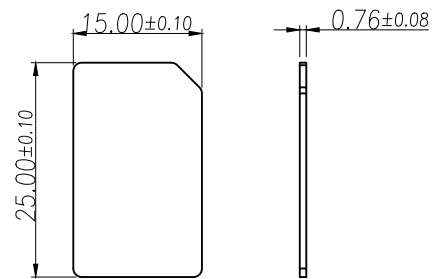

PIN/NO	ASSIGNMENT
C1	VCC
C2	RST
C3	CLK
C5	GND
C6	VPP
C7	I/O
CD1	POL
CD2	Detect Switch

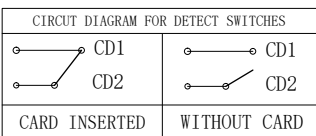

MILLIMETERS	INCH
X.° ± 2°	X.° ± 2°
.X ± 0.30	.X ± 0.012
.XX ± 0.20	.XX ± 0.008
.XXX ± 0.10	.XXX ± 0.004

DRAWN BY: Zou Long  
 CHECKED BY: Bob  
 APPROVED BY: QPF



FOR YOUR VITAL CONNECTION

TITLE:	1. 80H Push-Push SIM Card		
PART NO:	VTC102011322	REV: A	FCN: E1
SIZE: A4	UNIT:mm	SHEET:1 OF 2	FCN: E1
PROJECTION		http://www.vitalconn.com	

# RoHS Compliant

7		8	
REV:	ECN. NO.	NAME	DATE

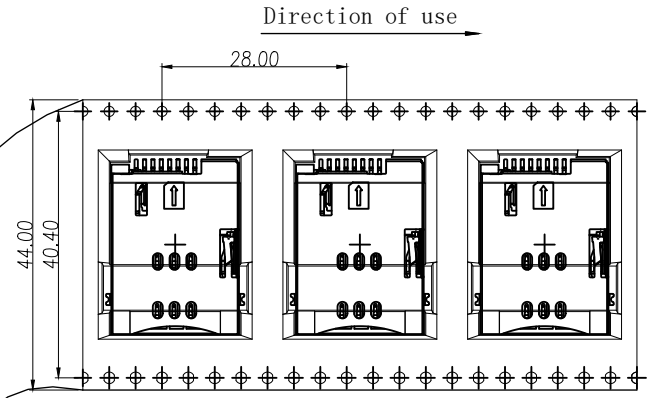

NOTES:

- 1、Packing quantity per plate: 550PCS/Plate
- 2、Loading and packing method

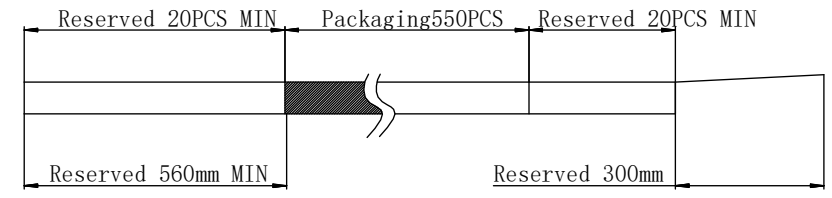

3、Total packaging: 3300PCS/Box

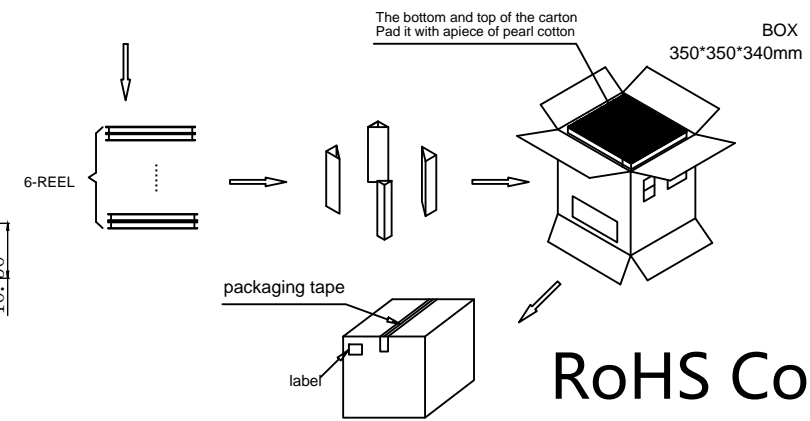
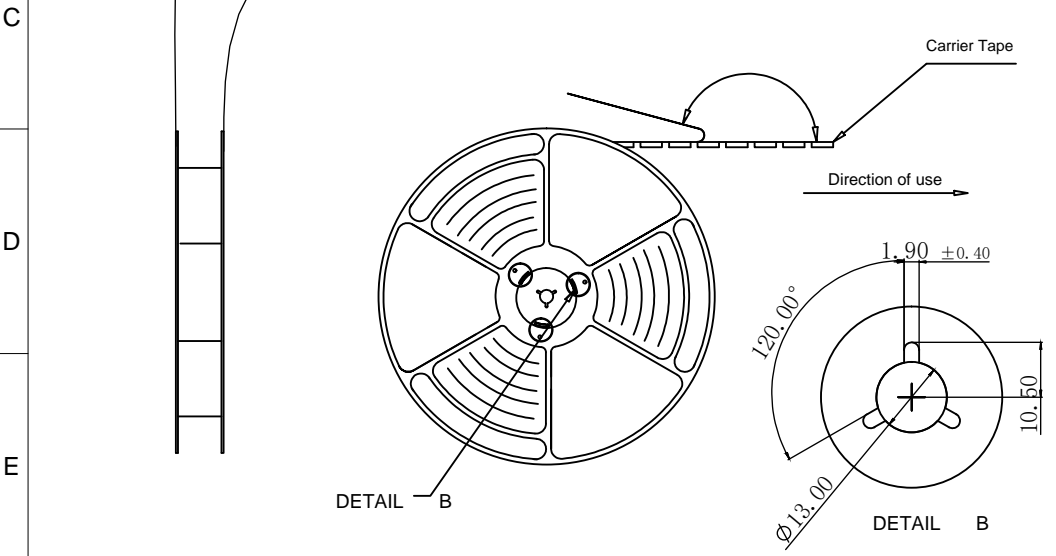

**RoHS Compliant**

Part Number	Description	Quantity
303020050	Carrierband Lucent PET W=44 PH=28,T=0.3	99.12m
303040009	Box K=K,T=7.0,350*350*340	1PCS
303060001	PE Bag T=0.08mm 730*760*730	1PCS
303070015	Self-adhesive W=37.50	100.92m
303110001	Beam K=K T=7.0,95*95*290	4PCS
303130001	Pearl Wool 340*340*18	2PCS
303180020	REEL BLUE 13Inches*44mm φ330	6PCS
VTC102011322	1.80H Push-Push SIM Card<SM006-020>	3300PCS

MILLIMETERS X.° ± 2° .X ± 0.30 .XX ± 0.20 .XXX ± 0.10	INCH X.° ± 2° .X ± 0.012 .XX ± 0.008 .XXX ± 0.004		FOR YOUR VITAL CONNECTION	
DRAWN BY: Zou Long			TITLE: 1.80H Push-Push SIM Card	REV: A
CHECKED BY: Bob		PART NO: VTC102011322	UNIT:mm	SHEET:2 OF 2 FCN: E1
APPROVED BY: QPF		PROJECTION	<a href="http://www.vitalconn.com">http://www.vitalconn.com</a>	